

VALLEY SPRINGS PUBLIC UTILITY DISTRICT



IMPROVEMENT STANDARDS

WATER

WASTEWATER

Valley Springs Public Utility District
PO Box 284
Valley Springs, California 95252

SEPTEMBER 2013



VALLEY SPRINGS PUBLIC UTILITY DISTRICT

PO BOX 284 ♦ VALLEY SPRINGS CA 95252

(209) 772-2650 ♦ FAX (209) 772-3069

RESOLUTION NO. 13-02

A Resolution Approving 2013 Improvement Standards

WHEREAS, All improvements proposed for acceptance into the District maintained systems must be constructed in accordance with District Improvement Standards; and

WHEREAS, Improvement Standards have been updated to the 2013 edition.

NOW, THEREFORE, BE IT RESOLVED that the 2013 Improvement Standards are satisfactory and hereby accepted and approved.

The foregoing resolution was duly approved and adopted by the Board of Directors of Valley Springs Public Utility District at a regular meeting on the 23rd day of October, 2013, by the following vote:

AYES: Whitaker, Gleason, Cardenas & Allee

NOES: none

ABSENT: Robertson

ABSTAIN: none

A handwritten signature in blue ink, appearing to read "Paul H. Allee", is written over a horizontal line.

Board President

ATTEST:

A handwritten signature in blue ink is written over a horizontal line.

Secretary, VSPUD

IMPROVEMENT STANDARDS

September 2013

Resolution No. 13-02

TABLE OF CONTENTS

1.00 PURPOSE AND INTENT	1
2.00 DEFINITIONS	2
3.00 GENERAL REQUIREMENTS	5
3.01 PLANS AND SPECIFICATIONS REQUIRED.....	5
3.02 STANDARD SPECIFICATIONS.....	5
3.03 PLAN SUBMITTAL.....	5
3.04 CHANGE IN PLANS DURING CONSTRUCTION.....	6
3.05 CONTRACTOR AND DEVELOPER RESPONSIBILITY.....	6
3.06 MAINTENANCE GUARANTEE.....	6
3.07 DIRECTIVES OF INSPECTOR AND DISTRICT ENGINEER.....	7
4.00 PLAN DETAILS	8
4.01 GENERAL.....	8
4.02 PLAN CONTENT REQUIREMENTS.....	8
4.03 PLAN FORMAT REQUIREMENTS.....	10
4.04 ADDITIONAL IMPROVEMENTS TO BE SHOWN.....	10
4.05 COMPLIANCE.....	10
5.00 INSPECTION DURING CONSTRUCTION	11
5.01 GENERAL.....	11
5.02 LOCATE AND PROTECT EXISTING UTILITIES.....	11
5.03 NOTIFICATION.....	11
5.04 COMPLIANCE AND RESPONSIBILITY.....	11
5.05 INSPECTION FEES.....	11
5.06 INSPECTION DEPOSIT.....	12
6.00 FINAL INSPECTION	13
6.01 CLEAN UP.....	13
6.02 DISTRICT ENGINEER INSPECTION.....	13
7.00 “AS-BUILT” PLAN	13
7.01 “AS-BUILT” PLAN REQUIREMENTS.....	13
8.00 IMPROVEMENT AGREEMENTS AND SECURITY	14
8.01 IMPROVEMENT AGREEMENT.....	14
8.02 IMPROVEMENT AGREEMENT SECURITY.....	14
8.03 TERMINATION.....	14
8.04 DEPOSITS AND CERTIFICATES.....	15
8.05 LETTER OF CREDIT.....	15
8.06 PERFORMANCE AND LABOR/MATERIALS BOND.....	15
8.07 SECURITY RELEASE.....	15
8.08 TIME EXTENSION.....	15
9.00 DESIGN STANDARDS - SANITARY SEWER	16
9.01 GENERAL.....	16
9.02 CONTROL OF MATERIALS.....	16
9.03 CONNECTION TO FACILITIES.....	16
9.04 DESIGN FLOW.....	16
9.05 GRADIENTS.....	17
9.06 PIPE SIZE.....	18
9.07 PIPE STRENGTH CLASS.....	18

9.08	LOCATION AND ALIGNMENT	18
9.09	MINIMUM DEPTH	18
9.10	MANHOLE LOCATIONS	18
9.11	CLEANOUTS OR FLUSHING HOLES	19
9.12	STUBS FOR FUTURE EXTENSION	19
9.13	SERVICE LINES	19
9.14	LIFT STATION AND FORCE MAIN DESIGN	19
10.00	CONSTRUCTION STANDARDS - SANITARY SEWER	20
10.01	CONTROL OF WORK	20
10.02	SANITARY SEWER PIPE	20
10.02.01	<i>Pipes, Joints, & Fittings</i>	20
10.02.02	<i>Polyvinyl Chloride Pipe (PVC)</i>	20
10.02.03	<i>Force Main Pipe</i>	21
10.02.04	<i>Ductile Iron Pipe (DIP)</i>	21
10.03	INSTALLATION	21
10.04	TRENCHES AND BACKFILL	22
10.04.01	<i>Excavation</i>	22
10.04.02	<i>Bedding</i>	24
10.04.03	<i>Alignment and Grade Control</i>	24
10.04.04	<i>Backfill</i>	24
10.04.05	<i>Trench Safety</i>	27
10.05	PIPELINE TESTING	27
10.06	TESTS FOR OBSTRUCTIONS & TELEVISION LINE	28
10.07	MANHOLES	28
10.08	MANHOLE TESTING	29
10.08.01	<i>Vacuum Testing</i>	29
10.09	INSTALLATION OF CASINGS, BORING AND JACKING	30
10.10	CONNECTION TO EXISTING SEWER	30
10.11	SEWER LATERAL ADJUSTMENT TO GRADE AND SEWER LATERAL CONNECTION	30
10.12	CONCRETE STRUCTURES	31
10.13	CONCRETE AND PATCHING MORTARS	31
10.14	COUPLINGS AND SPECIAL FITTINGS	31
10.15	MISCELLANEOUS IRON AND STEEL	32
10.16	ADJUSTING UTILITIES TO GRADE	32
10.17	CLEANUP	32
11.00	DESIGN STANDARDS - WATER	33
11.01	GENERAL	33
11.02	REGULATORY STANDARDS	33
11.03	DESIGN REQUIREMENTS	33
11.03.01	<i>General</i>	33
11.03.02	<i>Preliminary Design</i>	34
11.03.03	<i>Final Design</i>	34
11.04	BENEFITING AREAS NOT INCLUDED WITHIN PROJECT BOUNDARIES	34
11.05	CALCULATIONS	35
11.06	DESIGN FLOW	35
11.06.1	<i>Municipal Flow Requirements</i>	35
11.07	PIPE SIZE	36
11.08	PIPE STRENGTH CLASS	36
11.09	LOCATION AND ALIGNMENT	36
11.10	MINIMUM DEPTH	37
11.11	SERVICE LINES	37
11.11.01	<i>Pressure Regulators</i>	38
11.11.02	<i>Backflow Prevention Devices</i>	38
11.12	STORAGE FACILITIES	38

11.12.01	General.....	38
11.12.02	In-Lieu Fees	39
11.13	TRANSMISSION LINE	39
11.14	DISTRIBUTION LINES.....	39
11.14.01	Design Flow Rate.....	40
11.14.02	Valving, Blow-Offs, and Air Release Valves	40
11.15	CREEK CROSSINGS	41
11.16	FACILITY MARKERS	41
11.17	CROSS CONNECTIONS	41
12.00	FIRE HYDRANT REQUIREMENTS.....	42
12.01	GENERAL REQUIREMENTS.....	42
12.02	MAIN TEE, RUNNER, AND GATE VALVE REQUIREMENTS.....	42
12.03	SUBSTITUTION OF MATERIAL	43
12.04	REBUILDING KIT	43
13.00	CONSTRUCTION STANDARDS – WATER.....	44
13.01	GENERAL	44
13.02	DUCTILE IRON PIPE (DIP)	44
13.03	POLYVINYL CHLORIDE PIPE (PVC).....	45
13.04	GATE VALVES.....	45
13.05	AIR RELEASE VALVES (ARV).....	46
13.06	SAMPLING STATIONS.....	46
13.07	VALVE BOXES (VB).....	46
13.08	THRUST BLOCKS	46
13.09	TRENCHES AND BACKFILL	46
13.10	PIPE LAYING	47
13.11	LOCATING WIRE.....	47
13.12	FILLING, TESTING, AND CHLORINATION OF PIPELINES	47
13.13	CONNECTION TO EXISTING LINES.....	49
13.14	COMPACTION TESTING.....	49
13.15	SERVICE CONNECTIONS	49
13.16	PIPE MATERIALS AND STORAGE.....	50
13.17	SAFETY	50
13.18	CLEAN UP	50
14.00	STANDARD DETAILS: SEWER & WATER.....	51

1.00 PURPOSE AND INTENT

It is the purpose of these Improvement Standards to provide minimum standards to be applied to improvements and private development projects to be dedicated to the public and accepted by the District for maintenance or operation, as well as improvements to be installed within existing rights of way and easements. These standards provide for coordinated development of required facilities to be used by and for the protection of the public. These standards shall apply to and regulate the design and preparation of plans for construction of water and sewer system facilities.

It is not possible to anticipate all situations that arise or to prescribe standards applicable to every development. The intent of these Standards is to assist developers, engineers, and contractors toward completion of improvements that will comply with District requirements and be accepted by the District for maintenance and operation. Any items or situation not included in these Improvement Standards shall be designed in accordance with accepted engineering practice, the applicable Standard Plans and Standard Specifications of the State of California Department of Transportation, and shall be subject to the approval of the District Engineer.

2.00 DEFINITIONS

In these Improvement Standards, the intent and meaning of the terms that are used shall be as defined in State Standard Specifications and as herein specifically noted.

ACCEPTANCE - The formal written acceptance by the District of an entire contract which has been completed in all respects in accordance with the plans and specifications and any modifications there of previously approved.

AGREEMENT, OR WATER SERVICE FACILITIES AGREEMENT - The formal Agreement between the District and Developer setting forth those mutual conditions, procedures, and requirements in connection with Improvements and Private works to be dedicated to the public and accepted by the District for maintenance and operation.

ANNEXATION - The inclusion of property within District boundaries by proper legal procedures.

AS-BUILT PLANS - “Record Drawings” signed and dated by the Consulting Engineer and the District Engineer, indicating that the plans have been reviewed and revised, if necessary, to accurately reflect “as-built” construction details.

BOARD - The Board of Directors of the Valley Springs Public Utility District, State of California.

CONSULTING ENGINEER - Any person or persons, firm, partnership, or corporation legally authorized to practice civil, mechanical, or electrical engineering in the State of California who prepares or submits improvement plans and specifications to the District Engineer for approval.

CONTRACTOR - The person or persons, firm, partnership, corporation, or combination thereof, licensed to perform the type of work involved, who has entered into a contract with any person, corporation, company, or his or their legal representative, for the construction of any improvement or portions of any improvement within the District.

COUNTY - The County of Calaveras, State of California.

DEVELOPER – The person or persons, firm, partnership, corporation, or combination thereof, financially responsible for the work involved.

DEVELOPMENT - Single properties as well as subdivision improvement.

DISTRIBUTION LINE - A public water supply line which has been or is to be constructed to distribute water to more than one service and is normally eight (8) inches or smaller in diameter.

DISTRICT - The Valley Springs Public Utility District.

DISTRICT ENGINEER - The Engineer authorized by the Board of Directors to represent the District or their authorized representatives.

FINAL APPROVAL - The stamp, "Plans Approved for Construction," on the plans, signed and dated by the District Engineer, indicates that plans have been approved by the District for construction.

IMPROVEMENT(S) OR IMPROVEMENT SYSTEMS - Those utility systems, as designated in the Agreement, to be dedicated to the public and accepted by the District for maintenance and operation.

IN-LIEU FEE - Where it is impractical to construct required improvements, and/or where, in the opinion of the District it is more practical to expand existing District Facilities rather than construct new improvements, Developer shall pay an "in-lieu" fee based on the estimated, or actual, cost of the required expansion of said facilities. An "in-lieu" fee may also be applicable where a Developer makes use of existing District facilities which have been sized to include such development and in which the development has not previously participated in the cost thereof.

INSPECTOR – The engineering or technical personnel authorized to act as agents for the District in the inspection of work covered by these specifications.

MANAGER - The person designated by the District Board to manage the District water and sewer systems and to perform the services or make the determinations and/or enforcements permitted or required under this Ordinance.

PLANS – Construction plans, including system maps, plans and profiles, cross sections, detail drawings, etc., or reproductions thereof, approved or to be approved by the District Engineer, which show the location, character, dimensions, and details for the work to be done.

RESIDENTIAL UNIT – That individual, residential unit wherein a single family does, or could reside.

RIGHT OF WAY – All land or interest therein which by deed, conveyance, agreement, easement, dedication, usage or process of law is reserved for, or dedicated to, the use of the general public, within which the District shall have the right to install, reconstruct, and maintain its facilities.

SERVICE, OR WATER SERVICE – The publicly owned and maintained portion of the water service line which links the water plumbing of a house or building with the distribution line. This publicly owned portion of the service line is normally ¾" or 1"

in diameter and normally extends from the distribution line to the meter box at the property line or right-of-way line.

SITE IMPROVEMENTS - Required improvements for projects other than subdivisions.

STANDARD DETAILS - The detail drawings at the back of these Improvement Standards.

STANDARD PLANS - The most recent volume of the State of California Standard Plans as issued by the Business, Transportation and Housing Agency, Department of Transportation, State of California.

STANDARD SPECIFICATIONS - The most recent volume of the State of California Standard Specifications as issued by the Business, Transportation and Housing Agency, Department of Transportation, State of California.

STATE STANDARD DRAWINGS - The most recent Standard Drawings and Plans of the State of California, Business and Transportation Agency, Department of Transportation.

SUBDIVISION - That certain real property for which the Developer has entered into an Agreement with the District in connection with improvements and private works to be dedicated to the public and accepted by the District for maintenance and operation. As defined herein: Subdivision shall include all such real property as described in said Agreement, whether or not said real property is as defined as a "Subdivision" in the Calaveras County Subdivision Ordinance, Title 16, Calaveras County Code, or the State Subdivision Map Act.

TRANSMISSION LINE - A public water supply line which has been or is to be constructed to transmit water to more than one distribution line, and is normally ten (10) inches or greater in diameter, and to which services are not normally connected.

WORK - All the work to be done under District permit or inspection, whether in or out of contract, in accordance with the plans, specifications, and/or special provisions and/or permit conditions.

3.00 GENERAL REQUIREMENTS

3.01 Plans and Specifications Required

Complete plans and specifications shall be prepared by an Engineer for all proposed water and sewer system improvements. All plans and specifications for improvements to be accepted for maintenance by the District shall be prepared by an Engineer of the appropriate branch of engineering covering the work submitted. All dedications and easements necessary to accommodate all improvements shall be submitted to the District Engineer for approval and offered for dedication to the District. Possession of a complete set of District approved plans and a valid Calaveras County encroachment permit shall constitute the necessary permits for a Contractor to perform any work. Engineer or his representative shall order the Contractor to cease work on any project when the Contractor does not have properly approved plans in his possession. Contractor shall be duly licensed by the State of California, and shall be bonded as required to meet the requirements of the District.

3.02 Standard Specifications

The Standard Specifications shall be made a part of contract documents by note or reference which shall appear in the Special Provisions and in the General Notes on the plans. The note or reference shall be as follows:

“The Standard Specifications are part of the contract documents of this project and all materials and construction shall be in strict conformance with said Standard Specifications or as authorized by these plans.”

3.03 Plan Submittal

Three sets of plans for subdivisions and three sets of plans for site improvements, complete and in accordance with these Improvement Standards and the Standard Specifications, shall be submitted along with any required specifications, computations, test data, and other material required by the District for approval.

When the plans are initially submitted to the District, a plan check fee in accordance with Table I, will be required as a deposit to initiate checking of the plans by the District. Whenever the plan check fee deposit is exhausted, the Developer shall deposit additional funds to complete the plan check process. When the total plan check charges are less than the deposit, the balance will be returned to the applicant after the improvements have been certified as complete by the District Engineer and all conditions of approval complied with.

Should there be required alterations or revisions to the plans as submitted, one copy will be returned with the required corrections marked or indicated thereon. Plans not prepared in accordance with these Improvement Standards and the Standard Specifications or plans not prepared consistent with the standards of the profession, may be returned unmarked and unapproved.

No plans will be approved nor construction authorized until such times as all appropriate District Official(s) signify approval on the plans. All changes, corrections, or additions required shall be resubmitted to the District for approval as prescribed. At such times when the plans meet the requirements of the District and the plan check and inspection fees have been paid, the plans will be signed by the District Engineer. The Engineer shall deliver not less than two complete sets of plans to the District Engineer which will be retained by the District.

Excepted from approval are any features of the plans that are contrary to or in conflict with any California State Law, District ordinance or resolution, generally accepted sound engineering practice, or standards of the profession; even though such errors, omissions or conflict may have been overlooked in District review of the plans.

3.04 Change in Plans During Construction

Should changes become necessary during construction, the Engineer shall resubmit “red lined” plan sheet prints for approval by the District. Necessary changes shall be clearly shown and dated on the plans. Minor changes, which do not affect the basic design or contract, may be made upon the authorization of the District Engineer. All changes shall be shown on “as-built” plans when the work is completed.

3.05 Contractor and Developer Responsibility

Contractor and Developer are directed to the Construction Safety Orders of the Division of Industrial Safety. Contractor and Developer shall conduct all work in accordance with these standards. Contractor and Developer shall be responsible for all damage arising from any failure to comply with such orders regardless of any action taken by the District or its authorized agents.

Contractor and Developer are directed to the regulatory provisions of the State Standard Specifications. District will assume no costs or liability for complying with these provisions.

The Developer, the Engineer, and the Contractor shall keep themselves fully informed of and shall comply with all applicable federal and state laws in addition to all county and municipal ordinances, resolutions, rules and regulations which in any manner affect the design, construction, or operation of the project or its appurtenances.

It shall be the responsibility of the Developer to obtain all approvals required from applicable public agencies regarding the proposed construction. Such agencies may include but are not limited to California Department of Fish & Game and the Central Valley Regional Water Quality Control Board.

3.06 Maintenance Guarantee

Developer or Contractor shall guarantee the entire work required by the District to be free of defects in materials and workmanship for a period of one (1) year following the date of acceptance of work by the District. Developer or Contractor shall make, at their expense, any repairs or replacements made necessary by defects in materials and workmanship which become

evident within guarantee period. The Developer or Contractor shall indemnify and save harmless the District and officers, agents, and employees of the District against and from all claims and liability arising from damage and injury due to said defects. The Developer shall cause all repairs and replacements to be made promptly upon receipt of written order from the District. Should Developer fail to have repairs and replacements made promptly, District shall cause the work to be done, and the surety provided therefore shall be claimed for the cost of all such work.

Maintenance guarantee shall be a surety bond or other approved security which shall be delivered to District prior to recording of a final map or other approval requested of District. Said security shall be in an approved form and executed by a surety company or companies satisfactory to District in the amount of ten percent (10%) of approved engineer's estimate of construction costs. Security shall remain in force for the duration of the guarantee period specified. In lieu of providing security as prescribed above, the Developer may provide for the Faithful Performance Bond under agreement to remain in force until the expiration of guarantee periods.

Specific guarantees for periods longer than one (1) year may be specified due to special conditions of materials or workmanship.

3.07 Directives of Inspector and District Engineer

The District Engineer, or his approved representative, shall decide all questions concerning quality or acceptability of materials furnished and work performed, manner of performance, rate of progress, interpretation of plans and specifications, and all questions as to the acceptable fulfillment of the contract by the Contractor. The District Engineer's decision shall be final, and he shall have the authority to enforce and effectuate such decisions and orders should the Contractor fail to carry out said orders in a timely manner.

On all work where a private Engineer has furnished the design or been designated Engineer of Work by the District, their approval of proposed changes, materials, quality of work, manner of performance, rate of progress, and interpretation of plans and specifications shall be sought and obtained in addition to the approvals granted by the District Engineer.

4.00 PLAN DETAILS

4.01 General

All plans submitted to the District shall be prepared in a manner that will produce legible prints. All line work must be clear, sharp and heavy. Letters and numerals shall be 1/8 inch minimum height, well formed, and sharp. Numerals showing profile elevations shall not be bisected by station grid lines. Computer drafting shall be by clear and legible lettering acceptable to District.

4.02 Plan Content Requirements

The following requirements shall apply to all plans submitted for approval. Engineer shall prepare plans neat, accurate, and comprehensive in keeping with the standards of the profession. Engineers are directed to State Standard Plans.

A. Title Sheet

On subdivision or improvement plans, exceeding three sheets in the set, a title sheet shall be prepared showing the entire subdivision or project complete with subdivision or assessment district limits, District limits, street names, section lines, corners, and the location within the District. (Minimum scale 1"=500'.) The title sheet shall also include an index of the sheets; Engineer's name, license number, and signature; the date and scale of the drawing; north arrow; and the block for the necessary approval of the District Engineer and other officials. All sheets shall be 24" x 36".

B. Layout Sheet

The layout sheet (Sheet 2) shall contain thereon the entire subdivision on one sheet in skeleton form with drainage features, sewer and water lines, and other underground utilities shown. Drainage pipe, sewer pipe, water lines, and other underground utilities shall each be identifiable from other underground conduits. Appurtenances such as manholes, valves, and drop inlets shall be shown in their proper location. The scale of the project shall be 1" = 100' or 1" = 200'. An index of the plan and profiles sheets shall be shown on the layout sheet.

C. Title Blocks

Each sheet within the set of drawings shall show the sheet title, sheet number, date, scale, and the Engineer's name, signature, and license number.

D. Right of Way

Right-of-way lines, the boundaries of lots fronting on the street, drainage easements, utility easements, planting easements, section lines and corners, and temporary construction easements both existing and proposed shall be shown on the plans. All right-of-way and easement lines shall be properly dimensioned.

E. Topography

All pertinent topographic features shall be shown such as street lines, curbs, sidewalks, shoulders, location and size of storm and sanitary sewer lines, high water and frequent inundation levels, water lines, gas lines, telephone conduits, other underground utilities, existing structures, houses, trees (6" and larger) and other foliage, traffic signals, street lights, pull boxes, underground electrical conduits, drainage ditches, utility poles, fire hydrants, retaining walls, masonry structures, and all other features in the area which may affect the design requirements for the area.

F. Profiles

Plans shall show the profile of all existing roadway centerlines, existing edges of pavement, existing curb and gutter flow lines, water and sanitary sewers. All profiles of proposed improvement shall state centerline elevations at fifty (50) foot intervals and rate of grades, vertical curves and other vertical alignment data. Elevations of any warped surfaces shall be set at twenty-five (25) foot intervals. When required by the District Engineer, the Engineer shall provide centerline profiles and cross section information beyond the limits of the proposed development to facilitate setting proper vertical alignment within the proposed improvement limits.

G. Stationing and Orientation

The stationing on plan and profiles sheets shall read from left to right. Plans shall be so arranged that the north arrow points toward the top or upper 180 degrees of the sheet, insofar as practical.

H. Bench Marks

The bench marks and datum shall be clearly noted on the plans both as to location, description, and elevations. The datum shall be U.S.G.S. or otherwise approved by the District Engineer.

I. Typical Sections

A typical section, setting out the structural features for each type of facility within the improvement, shall be set forth on the plans.

J. Cross Sections

Cross sections, when required, shall be included with the plans. When, in limited areas, unusual topographic features or special conditions occur that would affect the work, individual cross sections or typical sections may be shown on the pertinent plan sheet.

K. Special Notes

Special notes shall be clearly indicated and it shall be conspicuously noted on the plans that all construction work and installation shall conform to the State Standard Specifications, the District's Improvement Standards, and that all work is subject to the approval of the District Engineer. Notes shall contain a statement that the Contractor shall verify the existence and locations of all utilities.

4.03 Plan Format Requirements

All improvement plans shall be prepared on plan and profile sheets, 24" x 36". Scales: Horizontal 1" = 20', 40', or 50'; Vertical 1" = 2', 5', or 10'. Design cross sections plotted on 1" = 5' scale, taken on maximum 50' intervals shall be submitted with preliminary improvement plans or cut and fill slopes shall be shown on the plans. Cross sections shall be plotted with background grid with reference to identifiable base line or centerline.

Show all improvements in plan views. Underground facilities may be shown on a separate sheet but shall include an overlay of street improvements. Profiles of utilities shall be shown on the same sheet where plan views are provided.

4.04 Additional Improvements to Be Shown

Sanitary sewer and water improvements may be shown on the street plans or separately as indicated above. Location of all utilities shall be shown on the "as-built" plans.

4.05 Compliance

Plans shall be checked for compliance with these standards and all conditions of approval by the District Engineer. Plan checking deposit shall be as set forth in Section 5.04 of these standards.

5.00 INSPECTION DURING CONSTRUCTION

5.01 General

Any improvement which is intended for future District maintenance responsibility or required by District as a condition of approval, shall be constructed to District requirements and inspected during construction by the District Engineer. Each phase of construction shall be inspected and approved prior to proceeding to subsequent phases.

Inspection includes field inspection during the course of construction and materials testing of those improvements over which no other public agency or utility exercises inspection responsibility.

5.02 Locate and Protect Existing Utilities

This item of work shall cover the location and protection of ALL existing underground utilities as required under Section 4215 of the Government Code as amended and Section 11.06, "Obstructions," of these Improvement Standards.

Contractor shall locate existing utilities and pothole designated areas for location and protection of existing underground facilities within the project limits prior to start of work and as necessary to coordinate and schedule his work.

5.03 Notification

The Engineer shall notify the District Engineer when the Contractor prior to commencement of construction. Any improvements constructed without inspection as provided above or any construction contrary to the orders or instructions of the District Engineer shall be deemed not in compliance with District requirements and will not be accepted by the District.

5.04 Compliance and Responsibility

The District will inspect the work for ultimate compliance with the specifications but will not be responsible for the conduct of the work itself or the manner in which it is performed. Requirements of State or Federal agencies shall be verified by appropriate agency representatives.

5.05 Inspection Fees

The applicant shall deposit an estimated fee to cover the District's actual cost of inspection of the project. This fee may be deposited in two installments. The first installment shall be paid when plans are submitted for checking. The balance of the inspection fee shall be deposited prior to approval of the plans. All other public agency or utility fees shall be paid separately by the Developer. The inspection fee deposit shall be determined in accordance with Table I.

5.06 Inspection Deposit

Inspection deposits shall be placed in a plan check fund and all charges for inspection, as deemed necessary by the District shall be charged against that fund. No inspection work or construction work shall be undertaken when the cost of such inspection or work exceeds the funds remaining in the account for the project.

Whenever the inspection fee deposit is exhausted, the Developer shall deposit additional funds for further inspection work. When the total inspection charges are less than the deposit, the balance will be returned to the applicant after the improvements have been certified as complete by the District Engineer and all conditions of approval complied with.

TABLE I

FEE DEPOSIT AMOUNTS			
Total Estimated Cost of Improvements	Plan Check	Inspection	Total
Less than \$50,000	\$400.00	\$500.00	\$900.00
\$50,000 to \$99,999	\$1,000.00	\$2,000.00	\$3,000.00
\$100,000 to \$399,999	2%*	4%*	6%*
\$400,000 and over	1.75%*	3.75%*	5.5%*

*Percentage of Approved Engineer's Estimate of Improvement Costs.

6.00 FINAL INSPECTION

6.01 Clean Up

Upon completion of any improvements which are constructed under and in conformance with these Improvement Standards and prior to requesting a final inspection, the work area shall be thoroughly cleaned of all rubbish, excess material, and all portions of the work shall be left in a neat and orderly condition.

6.02 District Engineer Inspection

Within five (5) working days after receiving a request for final inspection, the District Engineer shall inspect the work. Contractor, Engineer, and Developer will be notified in writing as to any particular defects or deficiencies to be remedied. Contractor shall proceed to correct all defects or deficiencies at the earliest possible date. At such time as the work has been completed, an inspection shall be made by the District Engineer to determine if all defects have been repaired, altered, and completed in accordance with these Improvement Standards. At such time as the District Engineer finds the work acceptable, the District will be notified and the matter scheduled for Board approval. The Contractor, Engineer, and Developer will be notified in writing as to the date of final approval and acceptance by the Board.

7.00 “AS-BUILT” PLAN

7.01 “As-Built” Plan Requirements

One complete set of “as-built” reproducible plans and PDF electronic plans, as prescribed by the District Engineer, shall be submitted to the District Engineer prior to acceptance of the improvements.

Developer's Engineer shall keep an accurate record of all approved deviations from the plans. These are to be utilized with the Inspector's plans for preparing a complete and accurate set of “as-built” drawings for the permanent records of the District. “As-built” plans shall be prepared by the Engineer responsible for the work. Preparation of as-built plans, complete and in accordance with these standards, shall be the responsibility of the Developer.

8.00 IMPROVEMENT AGREEMENTS AND SECURITY

8.01 Improvement Agreement

When project improvements are not completed at the time the Final or Parcel Map is ready for approval by the Board, the applicant shall enter into an Improvement Agreement with the District. The agreement shall require the applicant to complete all conditions of approval and improvements as shown on the approved improvement plans within the time frame set forth therein.

8.02 Improvement Agreement Security

Applicant's performance under any such agreement shall be secured by a good and sufficient instrument of surety in an amount fixed by the estimated costs of the improvement in accordance with Table II. The estimate of construction costs shall be submitted to the District Engineer for review and approval. Security for District maintained improvements shall provide that ten percent of the secured amount be withheld by the District for a period of one year after the completion of improvements. The ten percent retention may be used by the District to correct any defects in material or workmanship which become evident in the one year period following completion.

TABLE II

AMOUNT OF AGREEMENT SECURITY			
TYPE OF SECURITY	PERFORMANCE	LABOR/ MATERIALS	TOTAL
Bonds	100%	100%	200%
Letter of Credit	75%	75%	150%
Bank Deposit (1)	75%	75%	150%
Deposit with District (2)	75%	75%	150%
(1) Savings account assigned to District.			
(2) Deposit in a trust account or a negotiable certificate of deposit with principal payable to the District upon demand.			

8.03 Termination

Termination date of any security shall extend beyond the termination date of the agreement or any extension thereof. Termination date shall be subject to the requirements of the Board.

8.04 Deposits and Certificates

Bank deposits and certificates of deposit shall be purchased or an account opened so that the principal and interest are payable to the District.

When the account or certificate is made jointly payable to the Developer and the District, the Developer shall submit a negotiable order of withdrawal with the bank book or an endorsed certificate.

8.05 Letter of Credit

The letter of credit shall be extended prior to its expiration date for any extension of time requested.

8.06 Performance and Labor/Materials Bond

Performance and Labor/Materials bonds shall be for the amount set forth in Table II. Performance and Labor/Materials bonds shall be provided by an “admitted California surety.”

8.07 Security Release

Security will be released upon request of the project proponent in accordance with the terms of these standards, the Subdivision Ordinance, and the Improvement Agreement.

8.08 Time Extension

Upon written request by the Developer, no less than thirty days prior to the expiration of the agreement, an extension of time may be requested from the District. To receive approval, the Developer shall have made a good faith effort to complete improvement requirements, or conditions or circumstances beyond their control such as weather conditions or litigation shall have prevented completion of the improvements. An extension of time of up to one year may be approved, provided the improvement security is adjusted subject to approval of the District Engineer.

9.00 DESIGN STANDARDS - SANITARY SEWER

9.01 General

These standards shall apply to all sewerage system facilities which are to be operated and/or maintained by the District.

9.02 Control of Materials

The Developer shall furnish samples of material as deemed necessary by the District Engineer for testing to verify conformance with manufacturer's specifications and District Standards. Samples shall be furnished at no cost to the District.

All tests of materials will be made in accordance with recognized standards of national organizations. The cost of testing for materials which are found to be in conformance with specifications and District Standards shall be charged as part of the inspection fee-deposit paid to the District. The cost of testing for materials which do not conform to specifications and District Standards shall be paid by the Developer in addition to the inspection fee-deposit paid to the District.

At the discretion of the District Engineer, materials may be approved for use when accompanied by a certificate of compliance stating that the material complies with all requirements of the specifications and District Standards. The certificate shall be signed by an officer of the manufacturer of the material. The certificate of compliance shall be furnished with each lot of material delivered to the work site, and the lot so certified shall be clearly indicated in the certificate.

All materials used in the basis of the certificate of compliance may be sampled and tested at any time. The certificate of compliance shall not relieve the Developer of responsibility for furnishing material which conforms to the requirements of specifications and District Standards. Any material not conforming to said requirements will be subject to rejection regardless of its stage of installation.

9.03 Connection to Facilities

No connections will be permitted to any portions of the system which is not completed in accordance with District Standards and accepted by the Board.

9.04 Design Flow

An average flow of 100 gallons per person per day or 350 gallons per dwelling unit per day shall be used for design of sewers with peak flows calculated using the factors from the peak flow factor chart (See Standard Detail SS-7). All sewers shall be designed to carry peak flows without surcharging the manholes.

The estimated population used for design, including population equivalents for commercial, industrial, and institutional uses, shall be submitted prior to commencement of improvement design.

Sewer mains subject to extension in the future shall be sized to serve the entire area tributary to the proposed development. The design engineer shall submit a study substantiating the proposed size of sewer in such cases. Discussion of parameters with the District Engineer is advised prior to the study.

9.05 Gradients

Sanitary sewer gradients shall be designed to provide a minimum flow velocity of two feet per second with pipes flowing half full. The following table indicates slopes which will provide that velocity. These shall be the minimum slopes for design of sanitary sewers unless flatter slopes are specifically approved by the District Engineer.

MINIMUM SEWER GRADIENTS

<u>DIAMETER</u>	<u>SLOPE (Ft/Ft)</u>
6"	.0050
8"	.0035
10"	.0025
12"	.0020
15"	.0015
18"	.0012
Service Line (4")	1/4 inch per foot (.020)

At changes in pipe size, the invert of the pipe flowing from the manhole shall be sufficiently lower than the incoming pipe in order that the inside crown elevation of both pipes is the same.

At manhole locations where angles of deflection occur in the alignment of the sewer, the pipe invert shall have a minimum drop from inlet to outlet according to the following table:

MINIMUM FLOW LINE DROP THROUGH MANHOLE

<u>ANGLE OF DEFLECTION</u>	<u>INVERT DROP (INLET TO OUTLET)</u>
0 to 45 degrees	.05 feet
45 degrees to 90 degrees	.10 feet
90 degrees plus	.20 feet

A drop manhole shall be constructed at any location where there is a drop in the sewer invert of more than 1.5 feet. Manhole structures used shall be in accordance with the Standard Details.

9.06 Pipe Size

Sewer pipe sizes shall be adequate to carry the peak design flows at the design gradient with a minimum size of 6 inch diameter except for service lines. Minimum size for main line sewers downstream of the last manhole on any given collector line shall be 8 inches unless otherwise approved by the District Engineer. Service lines shall be 4 inch diameter minimum except where estimated flow requires a larger size.

9.07 Pipe Strength Class

Manufacturer's specifications shall apply as to the proper class of pipe required for installation in the work except where these Standards are more stringent. Engineer may be required to substantiate the proposed class of pipe as required by the District Engineer.

9.08 Location and Alignment

All sanitary sewer facilities to be operated or maintained by the District shall be installed within right-of-way dedicated for public streets wherever possible. When facilities cannot be so located, they shall be installed within the center 10 feet of a 20 foot wide permanent public utility / public facility easement (PUE/PFE) dedicated or deeded to the District. In case of hardship in providing a 20 foot width, lesser widths may be approved on an individual basis. The location and width of easements shall be subject to approval by the District Engineer. A District standard "conveyance agreement" form shall be executed and fulfilled as well as all necessary easements deeded to the District at the time of the final submittal. Standard conveyance agreement form and easements shall be in accordance with the most current District Ordinance.

Where a curved alignment is necessary, the minimum radius of curvature shall be 400 feet. In no case shall the maximum deflection of pipe joints exceed the recommendation of the pipe manufacturer. Location of sewer lines relative to domestic water facilities and improvements shall be in accordance with applicable public health standards.

9.09 Minimum Depth

The depth of any sanitary sewer shall be adequate to provide a minimum cover of 2.5 feet in any traveled way. All service lines will, wherever practicable, be maintained at 2.5 feet cover at the property line. Minimum cover on service lines shall be 2.5 feet throughout the length of the line within the public rights of way.

Maximum depth shall not exceed 8 feet without the written consent of the District Engineer.

9.10 Manhole Locations

Manholes shall be constructed at all pipe line intersections except service lines, at angle points, at changes in pipe size or gradient, at the terminus of lines and at maximum intervals of 250 feet. Where manhole locations are fixed by intersections, the spacing of intervening manholes shall be approximately equal. All manholes shall have "all weather" vehicular access subject to the approval of the District Engineer.

9.11 Cleanouts or Flushing Holes

Cleanouts or flushing holes may be used in lieu of manholes at the terminus of any sewer where the distance from the terminus to the next manhole does not exceed 200 feet. Cleanouts on service lines shall be as shown on the Standard Details.

Temporary cleanouts may be installed at terminus of lines intended for future extension.

9.12 Stubs for Future Extension

Stub pipes shall be installed in manholes with appropriate plugs or caps, where shown on the drawings, for anticipated future extension and shall be extended to the project limits or across project frontage when required by the District Engineer. The location and size of stubs is subject to approval by the District Engineer.

9.13 Service Lines

Service lines from the main to the property line shall be installed for each and every residence or structure and include a flapper valve (backflow preventer check valve) and a cleanout. Service lines shall be in conformance with the applicable edition of the California Plumbing Code and these Improvement Standards.

The exact location of service lines passing under curb, gutter, and sidewalk shall be indicated with the letter "S" cast in the curb directly above the underground service line.

9.14 Lift Station and Force Main Design

Lift station and force main design shall be submitted by the Engineer along with supporting data and calculations. Discussion of parameters with District Engineer prior to design is advised.

10.00 CONSTRUCTION STANDARDS - SANITARY SEWER

10.01 Control of Work

A minimum of 2 work days (48 hours) notice shall be given to the District prior to commencement of the work. A minimum of 2 work days (48 hours) notice shall be given to the District prior to any phase of work requiring disruption of service. Connection to existing District facilities or conflicts with other utilities shall be approved by the District Engineer prior to the commencement of that phase of the work.

It shall be the Contractor's responsibility to ascertain possible conflicts with underground utilities, locate said utilities in advance of the work, and notify all applicable agencies and acquire any and all required permission and/or permits.

Underground facilities location requests, other than emergency, should be referred to Underground Service Alert of Northern California and Nevada (U.S.A.) toll free at 811. Surface marking on located underground facilities will be in accordance with the U.S.A. recommended color codes:

Blue	-	Water
Red	-	Electric
Yellow	-	Gas
Green	-	Sewer & Storm Drain
Orange	-	Communication & CATV

10.02 Sanitary Sewer Pipe

10.02.01 Pipes, Joints, & Fittings

All pipes, joints and fittings shall be of either ductile iron pipe or polyvinyl chloride plastic (PVC) materials as described below. Only one single type of pipe shall be used on any given project unless otherwise approved in writing by the District Engineer.

10.02.02 Polyvinyl Chloride Pipe (PVC)

Pipe shall be PVC gravity sewer pipe with integral wall, bell and spigot O-ring type joints. Pipe and fittings shall meet the extra strength minimum of SDR-35 in compliance with ASTM D3034 and shall be installed in conformance with ASTM D2321 or as modified herein. All fittings such as wyes, tees, bends, reducers, and connections shall be of the same material and manufacturer as the pipe. Rubber rings shall conform to ASTM designation D-1869. No solvent cement joints shall be used.

All PVC shall have a home mark to indicate full penetration at the spigot when the joint is made. PVC and fittings shall not be stored with direct exposure to sunlight for any extended period of time. If storage for a long period of time is necessary, pipe and fittings shall be covered with opaque material, providing for air circulation, or otherwise

protected in a manner approved by the District Engineer. Damaged pipe shall be removed and replaced. Field repairs to PVC pipe will not be allowed.

10.02.03 Force Main Pipe

All force main pipe shall be minimum 125 PSI PVC water pipe, ASTM designation D-2241, SDR 32.5 with rubber O-ring type joints. Rubber rings shall conform to ASTM designation D-1869. No solvent weld joints shall be used. Storage specifications apply as in subsection 15.02.02 above. The District Engineer may require C-900 PVC pipe where circumstances warrant.

10.02.04 Ductile Iron Pipe (DIP)

Ductile iron pipe shall be cement lined, and shall conform to AWWA Specification C151 and shall be Pressure Class 350 or approved equal. For sewer pipe, cement lining shall be high alumina or sulfate resisting. For storm drain pipe, cement lining shall be Portland cement-mortar.

10.03 Installation

Pipe shall be laid in strict conformity with the prescribed alignment and grade specified in the plans and these Improvement Standards, or as directed by the District Engineer. The pipe shall be brought to the site of work by a manufacturer's approved method. Before any length of pipe is laid, it shall be carefully inspected for defects. No pipe or other material that shows defect shall be placed. Pipe laying shall proceed upgrade with the bell ends of the pipe placed upstream. Each section of pipe shall be laid true to line and grade in such a manner as to form a water tight concentric joint with the adjoining pipe. The interior of the pipe shall be kept clear of all dirt and debris during construction.

All pipe laying and joining, including the maximum deflection of joints in curved alignment shall be in accordance with the pipe manufacturer's specifications and as directed by the District Engineer.

Bedding shall be shaped to fit the barrel of the pipe and give uniform support throughout its length. In the case of installing small diameter pipe, where practicable, the bedding may be shaped by lifting and dropping one end of the pipe in order to form the bed shape as described. Pipe bedding should be excavated from beneath the bell ends or couplings of the pipe so as to avoid any bridging effect. No wedging or supporting of the pipe with wood or any other type of material than the approved bedding shall be permitted.

Initial backfill shall be placed in an approved manner so the bottom one-third of the pipe rests on a dense compacted bed of approved granular material. Slicing with a shovel tip, tamping with a T-bar, compaction by foot, or other approved mechanical equipment may be used to meet such requirements. In case of light weight pipe (PVC), sufficient material must be placed on the pipe to keep it from moving out of line and grade.

Deflection for PVC pipe after installation shall not exceed manufacturer's recommended maximum deflection at any location. Should the installed pipe exceed manufacturer's recommended maximum deflection, each and every length of pipe so affected shall be removed and replaced.

Sewer service connections shall be connected to the new pipe with PVC wye compatible with the new sewer pipe. Mechanical saddles shall not be used. Contractor's attention is directed to Section 10.11, "Sewer Lateral Adjustment to Grade and Sewer Lateral Connection," of these Improvement Standards.

10.04 Trenches and Backfill

This work shall consist of performing all operations necessary to excavate earth and rock or other material, of whatever nature, including water, regardless of character and subsurface conditions, necessary to excavate trenches for pipes and appurtenances; to place backfill for structure, pipes and appurtenances and other facilities; to backfill trenches and depressions resulting from the removal of obstructions; to remove and replace unsuitable material; to construct protection dikes; and to remove unstable material and slide material which may enter trenches. All such work shall be in conformance with the approved plans and these Improvement Standards or as directed by the District Engineer. Typical trench details shall be shown on the plans.

Stripping of top soil and separate storage thereof will be required in areas where it is deemed necessary by the District Engineer to preserve the quality of top soil.

In connection with earthwork, all tests shall be made in conformance with the following requirements set forth in the State Standard Specifications:

<u>Tests</u>	<u>Test Method No</u>
Relative Compaction	Cal 216 & 231
Sand Equivalent	217
Resistance (R-value)	301
Sieve Analysis	202

10.04.01 Excavation

The Contractor shall furnish all materials and facilities required for trench excavation and shall make trenches and excavation dry throughout all pipe laying operations.

Except by specific approval of the District Engineer, no more than 300 feet of open trench shall be excavated in advance of laying of the pipe. Not more than 50 feet of trench excavation shall remain un-backfilled at the end of each day's work. The remainder of the trench shall be backfilled, compacted, and open to traffic where applicable. Should open trench be determined to be a safety hazard by the District Engineer, all trench excavation shall be backfilled at the end of each day's work. At the

end of each working day, all open trench shall be covered by means approved by the District Engineer, unless otherwise permitted by the District Engineer.

The trench widths set forth on the plans are minimum widths. No caving within the roadway will be permitted. Where excavation greater than the specified widths is necessary for execution of the work, machine or hand excavation to a stabilized slope will be permitted provided one-way traffic can be maintained. A minimum trench width is the distance face-to-face of trench walls or inside face to inside face of sheeting should solid sheeting be used. Maximum trench widths from the bottom of the trench to the top of the pipe shall be limited to six inches (6") outside the specified minimum trench width, except with specific approval by the District Engineer. Width of trench shall be uniform from top to bottom and shall be a minimum of 6" wider than the external diameter of the pipe. The maximum width of the trench measured at the top of the pipe shall not exceed the external width of the pipe plus 24 inches exclusive of bells, collars, and fittings.

Shoring of trenches shall be in accordance with appropriate State and Federal safety regulations and the dictates of good construction practice. Safe access to the trench for inspection purposes shall be provided at all times. The requirements of California Division of Industrial Safety shall be complied with. Instructions or lack thereof from the District Engineer or his representative in no way waives the Contractor's responsibility with regard to safety.

The depth of the trench shall be in accordance with the lines and grades shown on the plans with proper allowance for bedding and thickness of pipe and for the type of fittings specified. Any portion of the trench excavated below the proper grade shall be backfilled with approved bedding material and compacted to 95% relative compaction at the Contractor's expense and at the direction of the District Engineer. All areas of unsuitable material required by the District Engineer to be removed shall be replaced in the same manner.

Removal and disposal shall be required of all water entering the excavation. Disposal of water shall be done in a manner to prevent damage and nuisance to adjacent properties or to the public. Sufficient pumping equipment shall be provided in a manner so as to maintain the trench in a dry condition during the bedding and initial backfilling of pipe. Appropriate precautions shall be taken to prevent drainage water from entering any sewer line being constructed.

Where pipes are to be installed above original ground or in new embankment fills, embankment shall first be constructed to the required height for a distance on each side of the pipeline of not less than five feet (5'). Embankment shall have relative compaction of not less than ninety-five percent (95%). Upon completion and approval of the embankment the trench shall be excavated with the sides nearly vertical and the pipelines installed in accordance with these Improvement Standards.

Materials excavated from trenches shall be placed and maintained so as to offer minimum obstruction to traffic. Ditches shall be kept clear for the purpose of handling road drainage. Drainage ways, walkways, and driveways shall be kept clear at all times.

The location of underground utilities or other obstructions shall be determined by the Contractor sufficiently in advance of excavation so that pipe alignment can be confirmed or re-routed without delay. Contractor's attention is directed to Section 5.02, "Locate and Protect Existing Utilities," of these Improvement Standards.

10.04.02 Bedding

Bedding for the pipes shall be of a granular material appropriate to the conditions present in the construction. Depending on said conditions, native soil, clean sand, crushed or pit run gravel, pea gravel or road base may be required for pipe bedding. Type, method of placement, and preparation of bedding shall be approved in advance of the construction by the District Engineer, and any changes necessitated by the work or available supply of materials shall be approved by the District Engineer. A minimum of 6 inches compacted depth of bedding shall underlie the pipe in all cases. Bedding shall be placed and shaped to fit the underside of the pipe barrel with excavation made for bells or pipe couplings.

10.04.03 Alignment and Grade Control

The grade and alignment of the pipe shall be maintained by use of a method approved by the District Engineer in advance of the construction. The proposed method shall be submitted for review prior to commencing the work.

Horizontal alignment shall be such as to maintain a true line between manholes. Any deviation there from must meet the approval of the District Engineer.

Unless otherwise approved by the District Engineer, line and grade shall be staked by a registered civil engineer or licensed land surveyor. Staking shall be on minimum 50 foot intervals for straight lines and 25 foot intervals for horizontal and vertical curves. The District Engineer may at any time check the alignment and grade from staking. Contractor shall take appropriate means to preserve all stakes, benchmarks, and control used in the setting of alignment and grade. Where the District Engineer determines the loss of stakes and/or other reference points from whatever cause requires restaking, such restaking shall be performed when and as directed by the District Engineer and shall be done at the cost of the Contractor.

10.04.04 Backfill

When a firm foundation is not encountered due to soft, spongy, or other unsuitable material, such material shall be removed to the limits directed by the District Engineer, and the resulting excavation shall be backfilled with approved washed drain rock compacted to ninety-five percent (95%).

Foreign material which falls into the trench prior to or during placement of the backfill shall be removed. The size and nature of rock, if any, being placed in the trench backfill is subject to approval of the District Engineer. In no case shall roots, vegetable matter, or otherwise deleterious material be placed in the trench backfill.

Material for backfill shall be placed in uniform horizontal layers not exceeding one foot (1') in thickness before compaction, and shall be brought up uniformly on all sides of the trench, structure or facility. Backfill shall be placed in a manner so as not to damage the pipeline. When the Contractor can satisfactorily demonstrate to the District Engineer an alternative method of placing the backfill so that all requirements, other than the layer thickness, are met, the District Engineer may permit the Contractor to use the alternative method. Under no circumstance will the Contractor use the alternative method unless the District Engineer's approval is obtained in writing.

Each layer of backfill shall be compacted to a relative compaction indicated for the backfill involved. Compaction of Class 3 Backfill by ponding and jetting outside District or State rights-of-way will be permitted when the backfill material, as determined by the District Engineer, is of such character that it will be self-draining when compacted and that foundation materials will not soften or be otherwise damaged by the applied water and no damage from hydrostatic pressure will result. When ponding and jetting is permitted, material for use as Class 3 Backfill shall be placed and compacted in layers not exceeding three feet (3') in thickness. The work shall be performed in such a manner that water will not be impounded. Ponding and jetting methods, if allowed, shall be supplemented by the use of vibratory or other compaction equipment when necessary to obtain required compaction.

Backfill shall not be placed until the pipe or other facility has been inspected by the District Engineer and approved for backfilling. The percentage composition by weight as determined by laboratory sieves shall conform to the following requirements:

Class 1 Backfill

<u>Sieve Sizes</u>	<u>% Passing Sieves*</u>
3/4"	100
1/2"	30-50
No. 4	0-15
No. 6	0

Sand equivalent not less than 20

*Gradations requirements may be waived with written approval from the District Engineer.

“Pervious backfill” shall be coarse or medium screenings in accordance with Section 37, “Bituminous Seals,” of the State Standard Specifications or as otherwise approved by District Engineer.

Class 2 Backfill

Class 2 Aggregate Base, 1-1/2" maximum, shall be in accordance with Sections 26 of the State Standard Specifications except that percentage of No. 200 material shall be 15-30% unless otherwise approved by the District Engineer.

Class 3 Backfill

Material for Class 3 Backfill may consist of material from excavation free from rocks or lumps exceeding two inches (2") in greatest dimension, vegetable matter, and other unsatisfactory material. Backfill shall be compacted to the relative compaction shown on the plans or as set forth in these Improvement Standards.

Class 4 Backfill

Class 4 Backfill shall be a cement-sand slurry comprised of aggregate, cement and water. The aggregate, cement and water shall be proportioned either by weight or volume. Cement used shall be 190 to 210 pounds for each cubic yard of material produced. The water content shall be sufficient to produce a fluid workable mix that will flow and can be pumped without segregation of the aggregate while being placed.

Materials shall be thoroughly machine mixed in a rotary drum mix truck and placed in the trench from a direct truck discharge unless otherwise approved.

Mixing shall continue until cement and water are thoroughly dispersed throughout the material. All mixed slurry shall be placed within one hour of the introduction of water and cement to the material.

Aggregate shall be free of organic materials and other deleterious substances and have a minimum sand equivalent of 20. Aggregate shall conform to the following grading:

<u>Sieve Sizes</u>	<u>% Passing Sieves*</u>
1/2"	95-100%
3/8"	80-100%
#4	75-100%
#100	10-40%

Class 1 or Class 2 Backfill may be used as Class 4 Aggregate subject to the approval of the District Engineer.

The Contractor may use Class 4 backfill, slurry cement backfill, at locations approved by the District Engineer as an alternative to Class 1 backfill. Slurry backfill shall be placed to neat-line trench walls using care to completely envelope the pipe in the backfill. Road

surfacing will not be permitted until the District Engineer is satisfied that the set is sufficient to support traffic but in no case prior to setting four (8) hours.

The Contractor may use sufficient amounts of additives for speeding the set of slurry cement backfill in accordance with manufacturer's recommendations. No additive shall be used without prior approval of the District Engineer as to type and amount.

Slurry cement backfill shall be placed in a uniform manner that prevents voids in, or segregation of the backfill and will not float the pipe.

All trenches within paved roadways shall be backfilled with Class 4 backfill.

10.04.05 Trench Safety

Attention is directed to the provisions of Sections 6705 and 6707 of the Labor Code of the State of California.

Excavation for any trench five feet or more in depth shall not begin until the Contractor has received approval from the District Engineer of the Contractor's detailed plan for worker protection from the hazards of caving ground during the excavation of such trench. Such plan shall be submitted at least five days before the Contractor intends to begin excavation for the trench and shall show the details of the design of shoring, bracing, sloping, or other provisions to be made for worker protection during such excavation. No such plan shall allow the use of shoring, sloping, or a protective system less effective than that required by the Construction Safety Orders of the Division of Industrial Safety and if such plan varies from the shoring system standards established by the Construction Safety Orders, the plan shall be prepared and signed by an engineer who is registered as a civil or structural engineer in the State of California.

In addition, the Contractor shall obtain, pay for, and comply with all provisions of the permit required by Section 6500 of the California Occupational Safety and Health Act of 1973.

10.05 Pipeline Testing

Testing of pipe lines for leakage shall be done prior to acceptance of the completed facility. All pipe lines shall be air tested under the terms of the Ramseier Method as interpreted and reduced below.

The pipe line to be tested shall be plugged and pumped full of air to a pressure of not to exceed 4.0 psi above the average back pressure created by any ground water that may submerge the pipe. A stabilization period of not less than 5 minutes shall follow filling prior to beginning the test unless waived by the District Engineer. The pressure at the beginning of the test shall not be less than 3.0 psi. The allowable time for the pressure to drop a maximum of 0.5 psi is set forth below.

<u>Pipe Size</u>	<u>Allowable Time For 0.5 psi Drop</u>
4"	125 seconds
6"	185 seconds
8"	245 seconds
10"	306 seconds
12"	370 seconds
15"	460 seconds
18"	550 seconds
24"	735 seconds

If the pressure drop exceeds 0.5 psi over the time allowed, that section of pipe shall have failed the test and the Contractor shall locate and repair the faulty portion or portions and successfully retest.

Prior to air testing the Contractor shall satisfy the District Engineer that the lines are free of obstructions to the point that the air test is deemed valid by the District Engineer. Balling and flushing may be done at this time; however, balling and flushing is required after completion of all surface work.

Hydrostatic testing of lines may be substituted for air testing when approved by the District Engineer. The cost of retesting including inspector time shall be borne by the Contractor.

10.06 Tests for Obstructions & Televising Line

All sewer pipe lines shall be tested for obstructions and cleaned by balling and flushing and the lines televised. The ball shall be controlled by a tag line or rope or sewer rods and shall be permitted to move slowly through the sewer pipe. The ball shall be followed by a 5-point mandrel.

The ball shall be passed freely through the test section and all debris flushed ahead of it shall be caught and removed at the first downstream manhole. If the mandrel is stopped or prevented from moving freely by debris, damaged pipe, alignment, irregularity or any other cause, the Contractor shall locate and remedy or repair the obstruction and shall retest the conduit to the satisfaction of the District Engineer.

The Contractor shall televise all sewer mainlines after cleaning and testing and after all other roadway utilities are placed. Televised line footage for all installed mainlines shall be provided on DVD to District prior to acceptance of the work.

10.07 Manholes

All manholes shall be of concrete construction and shall be placed in accordance with the approved plans, and these Improvement Standards. Control of water in excavations shall be to the satisfaction of the District Engineer. Precautions shall be taken to assure that pipe entering and leaving manholes does not deviate from the installed alignment and grade during and after

construction. Ground beneath the manhole shall be compacted to 95% relative compaction prior to placing the base.

All manholes shall be precast concrete bases with precast reinforced concrete pipe sections, tapered sections, and adjustment rings. Reinforced concrete parts shall conform to ASTM designation C-478, and pipe sections shall be not less than 4 feet inside diameter.

Flex connectors at the inlet and outlet of sewer manholes shall comply with ASTM C-923. Sufficient material shall be placed on sewer lines to prevent movement.

Manhole joints shall be sealed against infiltration and exfiltration by means of sand-cement mortar between each joint, or by means of joint sealing compound as manufactured by the K.T. Schneider Co., Houston, Texas under the brand name "Ram-Nek," or "Quick-Seal," as manufactured by Associated Concrete Products, Inc., or approved equal. Appropriate primers and preparation as specified by manufacturer shall be used.

Manholes shall be finished inside and out with sand-cement mortar to produce a water tight, smooth finish. A smooth trowel finish shall be given to the surfaces of manhole base at flow line channel and to any joint mortar work. Excessive concrete, mortar, or improperly shaped or surfaced channels shall be chipped back and built up again to insure the proper shape and surface.

Sewer lift station manholes shall be 6' or 8' diameter with flat precast manhole cover. Cover shall have 6' x 3' aluminum access hatch cover cast into flat manhole cover. Covers shall be as manufactured by California Concrete Pipe, or Teichert Pre-Cast, or approved equal. Flat manhole cover shall be placed but not sealed.

Manhole cover shall have aluminum hatch, Series S3R, access door as manufactured by Halliday Products or approved equal. Hatch shall include locking bar, recessed lock box with spring assisted hinges. Clear opening shall be 36" x 72" except where a smaller size is allowed by District.

Backfill shall be placed uniformly around the outside of manholes so as to not create differential forces and the possibility of dislodging the manhole sections.

10.08 Manhole Testing

Manhole testing shall be by vacuum or water test.

10.08.01 Vacuum Testing

All lift holes and inside and outside joints shall be plugged with an approved non-shrink grout. All pipes entering the manhole shall be plugged, taking care to securely brace the plug from being drawn into the manhole. The test head shall be placed at the inside of the top of the cone section and the seal inflated in accordance with the manufacturer's recommendations. A vacuum of ten inches (10") of mercury (approximately 5 psi) shall

be drawn and the vacuum pump shut off. With the valves closed, the time shall be measured for the vacuum to drop to nine inches (9”).

The manhole shall pass if the time is greater than:

60 seconds for 48” diameter manholes

75 seconds for 60” diameter manholes

90 seconds for 72” diameter manholes

If the manhole fails the initial test, necessary repairs shall be made with a non-shrink grout while the vacuum is still being drawn. Retesting shall proceed until a satisfactory test is obtained.

10.09 Installation of Casings, Boring and Jacking

In case of installation of sewer line in a casing, whether by trenching methods or by boring and jacking, the grade of the installed casing shall be checked with regard to the design slope of the sewer being installed. The sewer line shall be installed by the method outlined in the Johns-Manville Sewer Installation Manual, latest edition, as amended by specific pipe manufacturer's recommendations and approved by the District Engineer.

The pipe skids shall be shaped and installed in a manner so as to compensate for any misalignment or grade problems in the installed casings. All procedures and equipment used in the installation of a sewer in the casing shall be subject to prior review and approval of the District Engineer. Any filling, stacking, drainage and protection of the casing ends shall be as directed by the District Engineer.

All requirements of agencies having jurisdiction over the highway, railroad, or other type of embankment through which the casing is placed shall be observed.

10.10 Connection to Existing Sewer

The Contractor shall connect to existing sewer at the locations shown on the plans in accordance with the approved plans and these Improvement Standards. The Contractor shall pothole existing facilities at the proposed points of connection prior to the commencement of construction to verify existing flow line elevations, pipe size, and type. The Contractor shall seal all connections into manhole barrel by use of an approved seal as directed by the District Engineer.

10.11 Sewer Lateral Adjustment to Grade and Sewer Lateral Connection

Existing sewer laterals with a top of pipe elevation within 0.10 feet of any storm drain flow line, shall be adjusted to a lower grade as directed by the District Engineer. Adjusting sewer laterals to grade shall include excavating existing laterals for a distance of not more than three feet on either side of the storm drain centerline, cutting and removing existing sewer lateral, placing new 4” diameter sewer lateral on a grade sufficient to pass under the storm drain, and reconnecting lateral couplings sufficient to provide a water tight connection.

Contractor shall during the course of work maintain at all times, materials, equipment, and labor to adjust, connect, or repair sewer laterals which are encountered during the course of the work. All sewer laterals broken during the course of work shall be repaired within one hour of break or as directed by the District Engineer. Contractor shall use all diligence necessary to remove foreign material from laterals and sewer line prior to repair or adjustment.

Contractor shall locate, expose, and plug existing sanitary sewer laterals to be abandoned with an approved water tight plug and shall encase plug end in not less than one (1) cubic foot of Class 4 backfill or Class B concrete. Water tight plug shall be inspected by District prior to placing encasement.

10.12 Concrete Structures

Concrete structures shall be constructed of Class A concrete and shall conform to the plans, the provisions in Section 51, "Concrete Structures," of the State Standard Specifications, and these Improvement Standards.

All concrete structures shall have smooth trowel finish in all flow lines and rounded inlets at all openings. Drainage inlet, junction box combination structures shall pass full pipe flow in concrete channel.

Concrete structures in roadways shall be backfilled with Class 2 backfill compacted to not less than ninety-five percent (95%) relative compaction. Concrete structures off road or behind concrete curbs shall be backfilled with Class 3 backfill at not less than ninety percent (90%) relative compaction.

10.13 Concrete and Patching Mortars

Concrete shall conform to State Standard Specifications and shall be Class B unless otherwise shown on the plans or specified herein.

Patching and sealing mortars shall be of a Portland cement base and shall be as of a type manufactured by Tamms Industries Co., Bellflower, California under the brand name "Speed-Crete or approved equal.

10.14 Couplings and Special Fittings

Couplings shall be double bell slip fittings of the same grade of pipe to be connected or approved equal. Flexible couplings shall be Fernco or approved equal and shall be subject to approval of the District Engineer.

Tapping saddles shall be of cast iron material, O-ring type seal with stainless steel bands or of approved PVC material with suitable seal and stainless steel bands or an approved flexible saddle. Tapping saddles shall be appropriate for the diameter and type of sewer being tapped and shall be subject to approval by the District Engineer.

Stub-out fittings for tapping shall be of the type specified for use with the specific size and type of pipe by the pipe manufacturer. Installation shall be in accordance with manufacturer's specifications and as approved by the District Engineer.

10.15 Miscellaneous Iron and Steel

Manhole frames and covers shall be cast iron in accordance with ASTM A-48, Class 35B with H20 loading rating and shall be California Concrete Pipe Model A-640/A-1024 or approved equal.

Manhole covers shall have raised lettering not less than 1" spelling out "VSPUD," cast into cover and center of each manhole shall spell out "Sanitary Sewer" with 2" lettering or as approved by District Engineer.

10.16 Adjusting Utilities to Grade

Contractor shall adjust existing manhole frames, water valve boxes, and water meter boxes affected by his work to grade in accordance with these Improvement Standards.

Manholes shall be adjusted to grade with cast iron riser rings and asphalt concrete backfill. Asphalt concrete shall conform Section 39, "Hot Mix Asphalt," of the State Standard Specifications and shall be ½" or ¾" maximum, medium grade, Type B aggregate as directed by the District Engineer, except it can be hand placed.

10.17 Cleanup

During the progress of the work the Contractor shall maintain the entire jobsite in a clean and orderly condition as required by all agencies having jurisdiction. The Contractor shall promptly attend to the concerns of any persons having contact with the work and shall repair or replace any damage caused by his operation as directed by the District Engineer.

11.00 DESIGN STANDARDS - WATER

11.01 General

This design criteria shall govern the engineering design of domestic water systems to be dedicated to the public and accepted by the District for maintenance and operation and for those systems designed for the District by its consultants.

It is the intent of these design standards to provide a water system that will dependably and safely convey the required amount of high quality water at adequate pressures and with minimum maintenance and operational costs.

Developers shall furnish, without cost to the District, all intrinsic and auxiliary water facility components necessary to provide a “complete and operational water system.”

11.02 Regulatory Standards

Pertinent requirements of the following agency standards, including all changes thereto, shall be considered and complied with in the design and construction of water system improvements. In the event conflict in these standards is found, the stricter design criteria shall govern.

- A. American Water Works Association (AWWA)
- B. Laws and Standards of the State of California, Department of Public Health.
- C. The Porter Cologne Water Quality Control Act, and the Regional Valley Water Quality Control Board, Central Valley Region.
- D. District Ordinances.
- E. National Board of Fire Underwriters' “Standard Schedule for Grading Cities and Towns of the United States,” as may be modified by the appropriate fire protection agency.
- F. Other standards as appropriate.

11.03 Design Requirements

11.03.01 General

The design for each water improvement project proposed to be dedicated to the District shall be submitted to, and approved by, the District Engineer in accordance with Section 3 of these standards. In addition to the general requirements of Section 3, the following specific requirements shall be complied with.

11.03.02 Preliminary Design

The preliminary design shall be submitted in the form of a map (and supporting calculations) to include the following:

1. Project area map that depicts project boundary and tributary areas between project and existing water facilities.
2. Contours over complete map and pressure zones. (5' contours minimum).
3. All main line locations and preliminary pipe sizes.
4. Residual pressures with design flows at major junctions, critical points, and different pressure zones. Static pressure shall not exceed 150 psi or be less than 40 psi at any point in the system.
5. Predicated design flows (peak and/or average as appropriate) at major junctions, including flows into and out of the project area.
6. Direction of flow under design conditions.
7. Land uses used to predict flows.
8. Special areas such as hospitals, schools, large office buildings, industrial, commercial areas, etc.
9. Boundaries of areas within the project which are tributary to points of major flow.
10. Location and sizing of major system components, including water treatment plant improvements, storage facilities, and pressure reducing valves if needed in the project.

11.03.03 Final Design

Final design shall be an expansion of the preliminary design in sufficient detail as to verify all preliminary sizing of facilities and to size those facilities not included in the preliminary design. All final design calculations shall accompany the construction plans and specifications submitted for review leading to "Approval for Construction." Static pressure shall not exceed 150 psi or be less than 40 psi at any point in system.

11.04 Benefiting Areas Not Included Within Project Boundaries

A parcel or area which benefits and participates in a project, but is not included within the project boundaries shall have a note to this effect placed on the overall project map and on the plan and profile sheet if the parcel appears thereon. Parcels not so noted which make use of a

project's facilities after the project's completion may be required to pay an “in lieu or buy in fee” prior to such use.

11.05 Calculations

The Hazen Williams formula shall be used in the hydraulic study of the system, using a “C” value as recommended by the pipe manufacturer. A Hardy Cross hydraulic analysis of any proposed distribution system shall be supplied to the District upon request.

11.06 Design Flow

Minimum design flows shall be determined by fire flow requirements. Generally, for single family developments, the minimum fire flows shall be 1000 GPM for 2 hours. For multi-family, commercial, and industrial developments, the minimum fire flow shall be 1500 GPM for 2 hours. These are minimum flow requirements. Additional considerations may be necessary, as set forth by the most current District resolution, the Fire Chief, and the District Engineer.

Design flows, including fire flows, shall be met with line velocities not exceeding 10 ft/sec at any time. The estimated population for design including population equivalents for commercial, industrial, and institutional uses shall be submitted prior to commencement of improvements design.

Water mains subject to extension in the future shall be sized to serve the entire area adjacent to the proposed development. The design engineer shall submit a study substantiating the proposed size of water mains in such cases. Discussion of parameters with the District Engineer is advised prior to the study.

11.06.1 Municipal Flow Requirements

A. Land Use

Flow determination shall be based upon the most recent or proposed land use. The minimum population density in areas of potential development shall be equivalent to that of single family residential use. All calculations shall assume full development, except where a staged concept has been specifically approved by the District.

B. Residential Living Units

Design population per living unit.

1. Developments of 100 living units and less. 3.5 persons per living unit.
2. Developments of greater than 100 living units. 3.0 persons per living unit.
3. Average daily flow for residential use shall be based on 150 gallons/day/person.

C. Commercial, Industrial Development

Flow requirements for commercial and industrial developments shall be based on specific development plans. In no case will water mains serving such areas be less than 8" in diameter.

D. Schools

School consumption shall be based on ultimate design, student population, plus administration, teaching, and operating personnel.

E. Average Daily Flow (ADF)

Average Daily Flow (ADF) shall be determined for service area(s) by multiplying the sum of the area(s) design population by the average per capita daily flow requirement, as designated above, plus any commercial, industrial, school, etc. contribution(s).

F. Maximum Daily Flow (MDF)

Maximum Daily Flow (MDF) shall be determined by multiplying the ADF by a factor of three (3). For projects of 50 dwelling units or more, multiply the ADF by a factor of two (2).

11.07 Pipe Size

Water pipe sizes shall be adequate to carry fire flow while not exceeding a velocity of 10 ft/sec. Minimum water main size shall be 6 inch diameter in any looped system. A 4" diameter main may be used on dead end lines where no fire hydrant or future extension will be made subject to the approval of the District Engineer.

Water service locations shall be approved by the District Engineer.

11.08 Pipe Strength Class

All pipe shall be not less than Class 150. When static working pressure exceeds 150 psi or other circumstances warrant, Class 200 pipe shall be used.

11.09 Location and Alignment

Water mains shall be installed within right of way dedicated for public streets where practicable. When not located in street rights of way, water mains shall be installed within the center 10 feet of a 20 foot wide permanent easement deeded to the District as a public utility / public facility easement. In case of hardship in providing the 20 foot width, lesser widths may be approved on an individual basis by the District Engineer. Water mains shall be designed to extend to the project limits or across project frontage when required by the District Engineer.

In no case shall maximum deflection of pipe joints exceed the recommendation of the pipe manufacturer.

All water mains in new developments shall be designed to be within the paved portion of the roadway, normally twelve (12) feet from any line, or in a public utility / public facility easement. All locations within existing road rights of way shall be approved by District Engineer. If it is necessary to install a water main within a private road, the easement shall be the width of the paving plus one foot each side, or 20 feet wide, whichever is larger.

Crossings of any sanitary sewer line or other non potable fluid facility shall be in accordance with State of California Department of Public Health's "Criteria for the Separation of Water Mains and Sanitary Sewers."

Waterlines shall be placed parallel to and 6 feet from either side of road centerline where pipe centerline radius complies with pipe deflection requirements. On short radius streets, alternate pipe locations will be allowed subject to approval of the District Engineer.

11.10 Minimum Depth

The depth of any water main shall be adequate to provide a minimum cover of 3.0 feet. All service lines shall be maintained at 2.0 feet of cover at the property line. Minimum cover on all service lines shall be 2.0 feet throughout the length of the line within public rights of ways or public utility easements.

11.11 Service Lines

Minimum service line size shall be 1 inch. Locator wire shall be installed with all service lines as shown in the Standard Details.

Service lines from the water main to the property line or edge of easement shall normally be installed at the time the main is constructed. Service lines from mains installed in private roads shall extend 10 feet (10') beyond the edge of the pavement. Meters and boxes shall not be located in driveways.

Service lines shall have a maximum length of one hundred (100) LF from the water main to the meter.

Commercial/Industrial customers shall have separate distribution line connections for domestic use and fire protection.

No service lines shall be permitted to tap into a fire hydrant lateral.

11.11.01 Pressure Regulators

Services with more than eighty (80) PSI static pressure shall be equipped with a pressure regulator set to sixty (60) PSI maximum. The regulator shall be installed outside of District right-of-ways on private property and owned and maintained by the property owner. Pressure regulator shall be installed at the time of service line construction.

11.11.02 Backflow Prevention Devices

Services on which the peak day pressure at the point of use is less than twenty-five (25) PSI shall be equipped with an individual backflow prevention device and hydropneumatic system. Backflow prevention device shall also be provided on all service connections to properties having a supplemental source of water, wells, fire sprinkler system, irrigation system that has an automatic chemical feeding control, pumps, or any other instance that has the potential to contaminate potable water supply or as directed by the District. Backflow prevention assemblies shall be installed outside of the right-of-ways on private property and be owned and maintained by the property owner.

Backflow prevention devices shall operate on the reduced pressure principle and shall consist of two spring-loaded check valves and a spring-loaded, diaphragm actuated, differential pressure relief valve located between two check valves. The backflow prevention assembly shall meet all applicable requirements of AWWA C511 and shall be included on the most current "List of Approved Backflow Prevention Assemblies" issued by the California Department of Public Health.

Residential reduced pressure backflow prevention assemblies shall be Wilkins 975XL2 or approved equal for 1" to 2" and Wilkins 375DAXL or approved equal for 4" or greater in accordance with Standard Detail WS-11. Commercial services shall be equipped with backflow prevention assemblies in accordance with Standard Detail WS-12.

11.12 Storage Facilities

11.12.01 General

Storage capacity shall be equal to the sum of fire storage reservation (FSR), plus the allowance for system peaking (SPA), plus an allowance for emergency reserve (ER). The minimum size storage tank shall be 250,000 gallons.

A. Fire Storage Reservation (FSR)

FSR shall be the product of the appropriate fire flow and the design fire duration. The minimum design fire duration shall comply with the requirements of the District.

B. System Peaking (Active) Storage (SPA)

SPA is a function of the system design and is twenty (20) percent of the total daily demand during the maximum day based on a 24 hour demand rate.

C. Emergency Reserve (ER)

ER shall provide sufficient capacity, without encroaching into the fire storage reservation or the active storage, to carry the system through reasonable periods of system failure. An emergency reserve increment of four (4) hour duration, based on the Maximum Daily Flow (MDF) shall be required. Isolated developments may require a larger increment and must be approved individually by the District.

Overflow Pipes must be sized to pass the maximum incoming flow rate with a design head of four (4) inches; head loss calculations must include both entrance and friction losses. Effluent must be directed to a natural water course in a manner that prevents scouring.

11.12.02 In-Lieu Fees

Where it is impractical to construct required facilities at the required elevations, or where in the opinion of the District it is more practical to expand existing facilities, Developer shall pay an “In-Lieu” fee based on required storage volume and current construction cost.

11.13 Transmission Line

The following requirements are applicable from a source to a storage facility where there are no services off the transmission line. Beyond the point of storage, or where storage is not available, or where services exist, the requirements of distribution lines normally apply.

Transmission lines shall be sized to pass the Maximum Daily Flow (MDF), plus fire flow. The Design Flow Rate shall be maintained to supply water from the source to the storage facility.

Transmission line valves shall be provided every 1800 lineal feet and any exceptions must be approved by the District. Air release valves shall be installed at all summits and blow offs shall be installed at all low points subject to the approval of the District Engineer. Whenever possible, valves shall be shown at locations similar to those locations as designated under distribution lines (below).

11.14 Distribution Lines

The following requirements shall apply to all water lines not classified as transmission lines. The distribution system, whenever possible, shall be in a looped grid form so that pressures throughout the pressure zone(s) become equalized under varying rates and locations of maximum demand. The pressures and flows as specified below shall govern design of the system.

11.14.01 Design Flow Rate

The distribution system shall be zoned to provide the pressure range set forth below. Lines shall be sized for the more rigid of the following conditions:

1. Minimum pressure 40 psi.
2. Maximum pressure 150 psi.
3. Fire Flow plus Maximum Daily Flow at 20 psi residual pressure.

11.14.02 Valving, Blow-Offs, and Air Release Valves

Air release valves, blow-offs, combination air release and vacuum release valves and other valves shall be placed on the plans and be incorporated in the design of pipelines in accordance with good engineering practice. Valve location, type, and size shall be subject to approval by the District Engineer. Sampling stations shall be provided where required by the District and shown on plans.

The distribution system shall be equipped with a sufficient number of valves so that no single shut down will necessitate the removal from service of a length of pipe greater than:

1. Five hundred (500) feet in a school, commercial, industrial, or multiple family dwelling areas.
2. Nine hundred (900) feet in other land use areas.
3. In no case shall more than two fire hydrants be removed from service.

The valves shall be located so that any section of main can be shut down without going to more than three locations to close valves. Valves shall preferably be located at street intersections. If it is necessary to install valves between street intersections, valve locations shall be established by the District Engineer.

A fire hydrant or blow-off assembly shall be installed on all permanent dead-end runs and at all low points in the system subject to the approval of the District Engineer. Wherever possible, fire hydrants shall be located to function as blow offs. Special attention shall be given to those of a temporary nature, taking into consideration the length of the dead-end run, the number of services on the line, and the estimated time before future extension. A minimum distance of 6 feet shall be provided between the last service and the blow off assembly on a dead-end run. See Standard Detail WS-4.

Blowoff assembly shall have a 2 inch vertical female iron pipe (FIP) inlet and 2 inch nipple for mains 6 inches and smaller or 4 inch vertical FIP inlet and 4 inch male iron pipe (MIP) outlet for mains 8 inches and larger. Blowoff assembly shall be operated by turning a top-mounted square operating nut. All internal working parts and the inlet and outlet fittings shall be manufactured from low-lead brass. All working parts shall be

serviceable from above without removal of the valve box. Blowoff assembly shall be Truflo Model No. TF550 (2-inch) or Model No. TF800 (4-inch) as manufactured by Kupferle Foundry or approved equal. Wherever possible, the blow off shall be installed in the road right of way outside the traveled way. In no case shall the location be such that there is a possibility of back-siphonage into the distribution system. Type of blow off installation shall be subject to the approval of the District Engineer.

All valves shall be flanged or flange x M.J. Use three (3) valves on all branch tees and four (4) valves on all crosses. Exceptions shall be shown on the plans and approved by the District Engineer.

Air release valves (ARV) shall be provided as follows:

1. At all high points in the system subject to the approval of the District Engineer.
2. At each end of long horizontal pipe runs.
3. At any point of significant pressure reduction.
4. At the low side of pressure reducing valves and every 2500-3000 feet of continuous pipeline.

11.15 Creek Crossings

Creek crossings shall be beneath the creek bed, concrete encased to the limits approved by the District Engineer, and constructed with Class 50 ductile iron pipe (DIP). DIP shall be wrapped with PVC prior to placing concrete encasement. When, in the opinion of the District Engineer, special circumstances warrant above ground creek crossings, the following requirements shall apply.

Crossing details of pipe, pier, anchorage, transition couplings, etc. shall be shown upon a detail sheet of the plans in sufficient scale for clear delineation of the work. Plans shall be submitted to the District Engineer for approval.

11.16 Facility Markers

Whenever any water facilities are located outside of traveled roadways, approved facility markers shall be installed unless otherwise approved by the District Engineer. Facility markers shall be placed every five hundred feet (500'), at horizontal angle points, valves, ARVs, blow offs or any other appurtenances. Facility markers shall conform to Standard Detail WS-15 and shall be shown on the plans.

11.17 Cross Connections

Cross connection installation shall be in accordance with AWWA standards. See Section 17, "Cross Connections," of the District's Rules and Regulations for additional information.

12.00 FIRE HYDRANT REQUIREMENTS

12.01 General Requirements

A. Scope

These requirements shall apply to all fire hydrant installations in the District. Fire hydrants installed on the metered side of private systems or on private property and not subject to District maintenance are exempt from these requirements.

B. Hydrant

Fire hydrants shall be dry barrel type and meet AWWA Standard C503. Unless otherwise indicated on the Plans or as required by the Fire Department, all hydrants shall have one four and a half inch (4½”) and two, two and a half inch (2½”) outlets with 5¼” inlet valve opening.

Hydrants shall be Clow Medallion. An approved equal to the fire hydrant may be installed provided that the District Engineer reviews and approves the fire hydrant in writing. The hydrant shall be yellow in color.

C. Bury

The hydrant bury length shall be consistent with the depth of the water main. It shall be buried to the depth indicated. Hydrant shall set plumb with the 4½” outlet facing the roadway. Runner to bury joint connections (AWWA C-900 PVC or AWWA C-151 Ductile Iron Pipe, identical in class to main) shall be a minimum of 6” in diameter. Contact shall be made with the Fire Department for specific requirements.

D. Thrust Block

All fire hydrants require a thrust block consistent with Standard Detail WS-13.

E. Location

Fire hydrants locations shall be at each intersection and at intermediate points in such a manner that the maximum distance between hydrants does not exceed 400 feet in residential zones and 200 feet in commercial areas, or as directed by the Fire Chief or Fire Marshal.

12.02 Main Tee, Runner, and Gate Valve Requirements

A. General

All main tees, runners, and gate valves shall be a minimum of 8” diameter.

B. Main Tees

Main tees shall be cast iron, flanged hub, and will be sized to match the pipe used. Fittings shall be a minimum of Class 125.

C. Runners

All runners shall match class of distribution line and shall not be less than C-900, Class 150 PVC or ductile iron Class 50 minimum pressure pipe. Pipe shall be tested and certified in California in accordance with appropriate AWWA specifications. The pipe shall be marked with the manufacturer's name, nominal inside diameter, and class or pressure rating. The maximum length of runners shall be 20 feet without prior approval of the Fire Chief and the District Engineer.

No fire hydrant shall be installed without a closed coupled gate valve shut off at the main line.

NOTE: Some fire hydrants, as delivered, have plugs installed in the drain openings. All drains shall be cleared prior to backfilling. Care should be taken to insure that thrust blocks do not obstruct drains. Any obstruction will require corrective measures at the Developer's expense.

12.03 Substitution of Material

Where the Developer proposes to use different materials or fittings other than specified, such materials shall be AWWA approved, and be approved in writing by the Fire Chief, Fire Marshal, and the District Engineer prior to installation.

12.04 Rebuilding Kit

For every one to five (1-5) hydrants installed, and for every five (5) hydrants thereafter, Contractor shall provide a complete rebuilding kit including but not limited to all special tools, o-rings, gaskets, seats, seals, caps, shear and clevis pins, bolts, nuts, nozzles washers, safety couplings, bonnets, stems, oils, sleeves, greases and break-a-way spool prior to the installation of the hydrant.

13.00 CONSTRUCTION STANDARDS – WATER

13.01 General

All materials, workmanship and miscellaneous items pertaining to water pipelines shall be in accordance with applicable AWWA specifications, the plans, and these standards.

All pipe, couplings and fittings shall be marked with the manufacturer's name, nominal inside diameter, class or pressure rating. Piping material and class shall be as specified herein and as shown on the plans.

Prior to any construction, the Developer and Contractor shall meet with the District Engineer or his representative to discuss the proposed construction. Additionally, a minimum of 48 hours written notice shall be given to the District Engineer prior to the beginning of construction and prior to any construction on District distribution lines. Except under emergency conditions, the Contractor will contact the District to open or close any District valves.

Any and all water to be used for construction shall be arranged through the District (209) 772-2650. All construction water charges shall be paid prior to acceptance of the job.

13.02 Ductile Iron Pipe (DIP)

Ductile iron pipe shall conform to AWWA C150 and C151 and shall be pressure class 350. Ductile iron pipes and fittings shall be Portland cement-mortar lined, and the lining shall conform to the provisions of AWWA Specification C104. Fittings shall be of ductile iron conforming to the requirements of AWWA Specification C153 with push-on joint bell design to fit the particular make of the pipe furnished or to fit a pipe-to-fitting adapter. Fittings shall have a pressure rating at least equivalent to that of the pipe used.

Buried pipe and pipe fittings shall all have restraint push-on joints (“Field Lok,” mega-lugs, flanged-in), unless otherwise specified. At fittings and tie-ins, pipe shall have push-on joints or mechanical joints. Mechanical joints may be used for closures, subject to meeting thrust restraint requirements. Flanged ends or plain ends with restrained couplings shall be used for piping above ground.

For mechanical joints, dimensional and material requirements for pipe ends, glands, bolts, nuts, and gaskets shall conform to AWWA C111. For flanged joints, ends of pipe and fittings shall be provided with ductile iron flanges conforming to AWWA C110 and C115, as applicable. All flanged connections shall use “Flange-Tyte” gaskets as manufactured by U.S. Pipe capable of withstanding pressures up to 350 psi.

Mechanical Joint hardware shall be high strength, low alloy (cor-ten). Bolts, nuts, and gaskets for flanged connections shall conform to ANSI B16.1. Bolts, nuts, washers, tie rods, and associated hardware used with flanged fittings, couplings, and appurtenances shall be Type 316 Steel for all buried and exposed applications. All bolts shall be furnished with finished hexagonal nuts. The dimensions of all heads and nuts shall be not less than those required for the American Standard regular, and the height shall be sufficient to break the bolt in the body

when tested. Threads shall be American Standard screw thread, coarse thread series. Type 316 Steel bolts and nuts hardware shall be used one time per application. Reusing Type 316 Steel hardware will not be permitted.

The interior of all pipe, fittings, and other accessories shall be kept clean and free from organic matter at all times. All pipes shall be delivered to the construction site with end-covers on both ends. End-cover components must adhere sufficiently to withstand the stresses caused by wind during shipment. Pipes delivered on-site with damage shall be immediately field cleaned to remove all undesirable material along the entire length of the interior of the pipe. New end-covers shall be installed after cleaning. Cut pipe lengths of 5 feet or less, fittings, and valves do not require end-covers but shall be field cleaned prior to installation.

Manufacturer's statement shall be provided to the District Engineer that the required inspection and tests have been made and found in compliance with applicable AWWA Specifications. Pipe shall be marked "DI" or Ductile Iron in accordance with Section 51-10 of AWWA Specification C151.

13.03 Polyvinyl Chloride Pipe (PVC)

Polyvinyl chloride pipe shall conform to the requirements of AWWA Specification C900-81.

Pipe shall be not less than Class 150 or Class 200 thick wall water pipe. All PVC pipe four inches in diameter or larger shall have elastomeric-gasket joints per Section 2.4 of AWWA Specification C900-81. Solvent-cement joints will not be allowed on pipe four inches in diameter or larger.

The class of pipe shall be not less than that shown on the plans.

PVC pipe less than four inches in diameter shall comply with ASTM D-2241 and shall have a wall thickness equal to or greater than Schedule 40 pipe. Solvent-cement jointed pipe shall have flexible joints at every 100 linear feet of pipe.

13.04 Gate Valves

Gate valves shall be Class 150 in accordance with AWWA C-509 and shall be iron body, gate type, resilient face, right hand, non rising stem, flanged with 2" square operating nut. Valve boxes including extensions and traffic covers shall have cast iron ring and traffic lids marked "water" (Christy G-5 or approved equal). Unless otherwise shown on the plans, or required by the particular installation, valves shall be furnished with mechanical joint or flange ends per Standard Detail WS-1.

All gate valves less than four inches (4") in diameter shall be Iron Body Bronze Mounted (IBBM) resilient seat valves and equipped with hand wheel unless otherwise specified by the District Engineer.

13.05 Air Release Valves (ARV)

Air release valves shall be installed at the locations shown on the plans and as approved by the District Engineer.

Air release valves shall be combination air vacuum (VAC-ARV) and shall release air from the line under pressure and allow air to enter the line under vacuum conditions. VAC-ARV valves shall be Bermad Model 4415 or equal. Valves shall be sized and installed according to manufacturer's recommendations and these standards per Standard Detail WS-8 and WS-9.

13.06 Sampling Stations

Sampling stations shall be installed at the locations shown on the plans and as approved or required by the District Engineer.

Sampling stations shall have a twenty-four inch (24") bury, with a three quarter inch (¾") FIP inlet and a three quarter inch (¾") hose or unthreaded nozzle. All stations shall be enclosed in a lockable, non-removable aluminum housing. When opened, the station shall require no key for operation, and the water will flow in an all brass waterway. All working parts will also be of brass or stainless steel and be removable from above ground with no digging. The exterior piping shall be brass or galvanized steel. A copper vent tube will enable each station to be pumped free of standing water to prevent freezing and to minimize bacteria growth. All piping shall be protected with closed cell pipe insulation, minimum 1" thick.

Unless otherwise approved by the District, all sampling stations shall be Eclipse #88 Sampling Station by Kupferle Foundry or equal per Standard Detail WS-10.

13.07 Valve Boxes (VB)

Valve boxes shall have a cast iron face and a cast iron traffic lid. Covers shall be marked "WATER" and shall have a loose fit in the box. Extensions shall be as furnished by the manufacturer. Valve boxes shall be installed in accordance with Standard Detail WS-1 and shall be Christy G-5.

13.08 Thrust Blocks

All valves, cast iron fittings and pipe directional changes shall be held in place by concrete thrust blocks. Thrust blocks shall consist of Class B concrete in accordance with Section 90 of the State Standard Specifications. The bearing areas shall be not less than the required area shown on the plans (see Standard Detail WS-13).

13.09 Trenches and Backfill

Water main trenches shall be constructed as noted in Standard Detail WS-5. See Section 10.04 of these improvement standards for additional trench and backfill requirements.

13.10 Pipe Laying

All pipe shall be laid true to line and grade as specified on the plans, or as directed by the District Engineer. Before any length of pipe is laid, it shall be carefully inspected for defects. No pipe or other material which shows defect, shall be placed. Pipes, valves and all fittings shall be new, clean and free of any foreign matter as they are laid. Pipes shall be plugged at the completion of each day's construction. The manner of plugging shall be approved by the District Engineer.

No deflection will be permitted at joints where water pipe is joined to cast iron fittings or valves. In areas where water pipe is not jointed to cast iron fittings or valves, deflection up to a maximum of four degrees after assembly will be permitted when "Ringtite" couplings are used for sizes up to twelve inches (12"). Rubber ring joints shall be field assembled in complete compliance with the manufacturer's recommendations. All pipe shall be inspected by the District Engineer or his representative prior to backfilling. The pipe in place shall permit thermal expansion of pipe ends through proper installation of pipe to pipe stop and not beyond pipe stop.

13.11 Locating Wire

Where all non-ferrous pressure pipe is installed in the ground, a locating wire shall be incorporated with the installation as specified herein.

Locating wires shall be insulated No. 12 solid copper, National Electrical Code type UF and shall form a mechanically and electrically continuous line throughout the length of the pipe. Conductors shall be spliced and insulated in accordance with Detail WS-1. The wire shall be laid in accordance with Standard Detail drawings and shall be carefully placed so as not to be broken or stressed by backfilling operations.

The Contractor shall test for the continuity of the locating wire at time of final walk-thru. The Contractor shall provide all labor, equipment and materials required for testing the continuity of the locating wire at each meter, valve, fire hydrant, blow off, ARV and sampling station. Should continuity not be present and/or observed, the Contractor shall repair, replace and retest as necessary, entirely at the Contractor's expense.

13.12 Filling, Testing, and Chlorination of Pipelines

All pressure piping shall be tested and chlorinated by the Developer at his expense. The Contractor shall provide all labor and materials required for hydrostatic and bacteriological testing, chlorination, and flushing. All testing and flushing shall be done under the direct supervision of the District. District personnel shall collect all test samples.

After the pipe has been installed and thirty-six (36) hours (for high early strength concrete; 7 days for Class B concrete) or more after placing all thrust blocks in the portion of the system to be pressure tested, the pipe shall be slowly filled with water as follows:

1. The line should be filled slowly, with flow velocity not to exceed 2 fps.

2. If possible, the line should be filled at its lowest point.
3. During filling, all air should be expelled through permanent air release valves at all high points.

After the pipe has been filled, it shall be allowed to set for a period of not less than twenty-four (24) hours. The pipe shall then be refilled to the original water level and subjected to a pressure of not less than 150 pounds per square inch or the service pressure plus 50 pounds, whichever is greater, measured at the lowest point in the line being tested. Such pressure shall be applied for a minimum period of two hours. Any part of the line which proves to be defective shall be replaced or repaired and retested. Pressure and leakage testing (combined) shall be as follows:

1. Purpose - a. Pressure test: to locate any defects in materials or workmanship so that repairs may be made; b. Leakage test: to establish that the section of the line tested will not leak, or that leakage is within acceptable limits.
2. Test Pressure and Duration - A test pressure of 150% of operating pressure is recommended. Test duration shall be 2 hours for a combined pressure and leakage test.
3. Method - The system should be raised to specified pressure by means of a pump connected to the pipe. The test pressure is maintained by additional pumping (if necessary), and all fittings, valves, and hydrants, carefully examined for leakage.

The maximum allowable leakage shall not exceed the amount determined as set forth below:

Leakage is defined as the quantity of water that must be supplied to maintain pressure within 5 psi of the specified pressure after the pipe has been filled, vented, and raised to test pressures. Allowable leakage may be calculated from:

$$\text{Allowable Leakage: } L = \frac{ND P}{7,400}$$

Where L = allowable leakage (gal./hr.)

N = number of joints in the tested line (pipe and fittings)

D = nominal diameter of pipe (in.)

P = average test pressure (psi)

Air pressure testing of PVC water pipe will not be allowed.

Following satisfactory pressure and leakage tests the system shall be chlorinated in accordance with the provisions of AWWA C601, "Disinfecting Water Mains," except there shall be a duration of forty-eight (48) hours.

A negative coliform test meeting the requirements of the Department of Public Health shall be made by a State approved bacteriological laboratory prior to acceptance of work. Water sampling for coliform tests shall be done by a State approved laboratory.

Retesting costs including inspector time shall be borne by the Developer.

13.13 Connection to Existing Lines

The District's emergency contractor or other contractor approved by the District Engineer shall make all connections into the existing distribution or transmission lines at the Developer's expense. A note to this effect shall be placed on each plan sheet which requires such connection. Developer shall coordinate all work on the existing pipe with the District. Developer shall provide a connection fee deposit to the District when application for a new connection is made. Actual costs of connection in excess of the fee deposit provided shall be paid by the Developer prior to receiving service.

Existing water line shall be out of service for no more than four (4) hours unless otherwise approved by the District Engineer. The Developer shall provide not less than twelve (12) hour notification to the District Engineer in writing prior to making any connection to existing mains. All materials shall be at the site prior to interrupting water service. No person other than a representative of the District shall open or close any valve in a District operated water system.

Connection to existing mains shall be with flanged and mechanical joint fittings only.

13.14 Compaction Testing

The Developer will provide compaction tests at various locations during the work as directed by the District Engineer. In the event of a test failure the Developer shall remove and re-compact unacceptable backfill or fills in accordance with the plans, specifications, and these standards at his expense.

THE COST OF RE-TESTING SHALL BE BORNE BY THE DEVELOPER.

13.15 Service Connections

Water service connections shall be placed in accordance with these standards.

One inch (1") services shall be housed in a 11 3/4" x 22 1/4" nominal sized utility box, Christy N16 or equal. One inch (1") service boxes shall be placed on a Christy B16SL concrete slab or equal. Meter box covers shall be reinforced concrete with a 5" x 8" self-closing reading lid, Christy B16G or equal.

Two inch (2") services shall be in a 17 1/8" x 30 1/4" nominal size utility box, Christy N36 or equal. Two inch (2") service boxes shall be placed on a Christy B36SL concrete slab or equal. Utility box cover shall be reinforced concrete with a 5" x 8" self-closing reading lid, Christy B36G or equal.

Meter boxes located in areas in the traveled way shall be traffic rated for H-20 loading minimum.

All meter boxes shall be rodent proof subject to the approval of the District Engineer.

Service saddles for PVC pipe shall be Ford FS 200 or approved equal. Service lines shall be C.T.S. size polyethylene water service pipe Class 200, 200 PSI minimum rated with an SDR of not greater than 9. Service saddles for ductile iron pipe shall be Ford F202 or approved equal.

Curb or angle stops shall be Ford locking type. Either curb or angle stops may be used but shall meet the cover requirement shown on the plans. Corporation stops shall be Ford F1100 (see Standard Detail WS-2).

Connection of new services to existing service lines is not allowed without prior written approval of the District.

13.16 Pipe Materials and Storage

All PVC pipe and fittings shall be stored to prevent direct exposure to sunlight. PVC pipe may be covered with opaque material, providing for air circulation, or otherwise protected in a manner approved by the District Engineer.

13.17 Safety

All construction procedures necessary to provide a safe working condition through all phases of the work shall be followed. Said procedures shall conform to the Safety Orders, Division of Industrial Safety, Title 8, California Administrative Code.

The Developer is solely responsible for outlining the safety procedures to be followed by his work force. The Developer shall provide for the safety of the public both day and night where they are exposed to the construction operation.

Neither the District, the District Engineer, nor any representatives thereof shall be responsible for the procedures followed by the Developer.

The Developer shall procure any and all permits in accordance with State laws and District requirements and shall pay all fees required.

13.18 Clean Up

The Developer shall at all times maintain an orderly and hazard free work area. The Developer will remove all construction debris, excavated materials in excess of fill requirements, and surplus materials not incorporated into the facilities as required by the District Engineer.

14.00 STANDARD DETAILS: SEWER & WATER

Index of Standard Detail Drawings

SANITARY SEWER DETAILS:

Sanitary Sewer Manhole	SS-1
Sanitary Sewer Manhole Cover	SS-2
Sanitary Sewer Service Laterals	SS-3
Cleanout Branch.....	SS-4
Trench Details	SS-5
Standard Force Main Details	SS-6
Peak Flow Factors	SS-7
Grease Trap with Grease Sampling Box.....	SS-8

WATER DETAILS

Valve and Locating Wire Installation	WS-1
Standard Service Connection	WS-2
Fire Sprinkler Service Connection	WS-2A
Water Meter Box Placement-Standard	WS-2B
Water Meter Box Placement-Slope	WS-2C
In-Line Blow-Off Assembly	WS-3
Dead End Blow-Off Assembly	WS-4
Pipe Trench Bedding and Back Fill	WS-5
Fire Hydrant & Blow Off Assembly.....	WS-6
Fire Hydrant Bollards	WS-6A
Typical Fire Hydrant Locations	WS-6B
Pressure Reducing Station Layout	WS-7
Air Release Valve	WS-8
1" or 2" Combination Air & Vacuum Release Valve.....	WS-9
Water Quality Sampling Station	WS-10
Residential Reduced Pressure Backflow Prevention Assembly	WS-11
Backflow Prevention Assembly for Fire Flow or Other Systems.....	WS-12
Thrust Block Details	WS-13
Casing & Carrier Pipe.....	WS-14
Water Facility Marker.....	WS-15
Water Separation Standards.....	WS-16

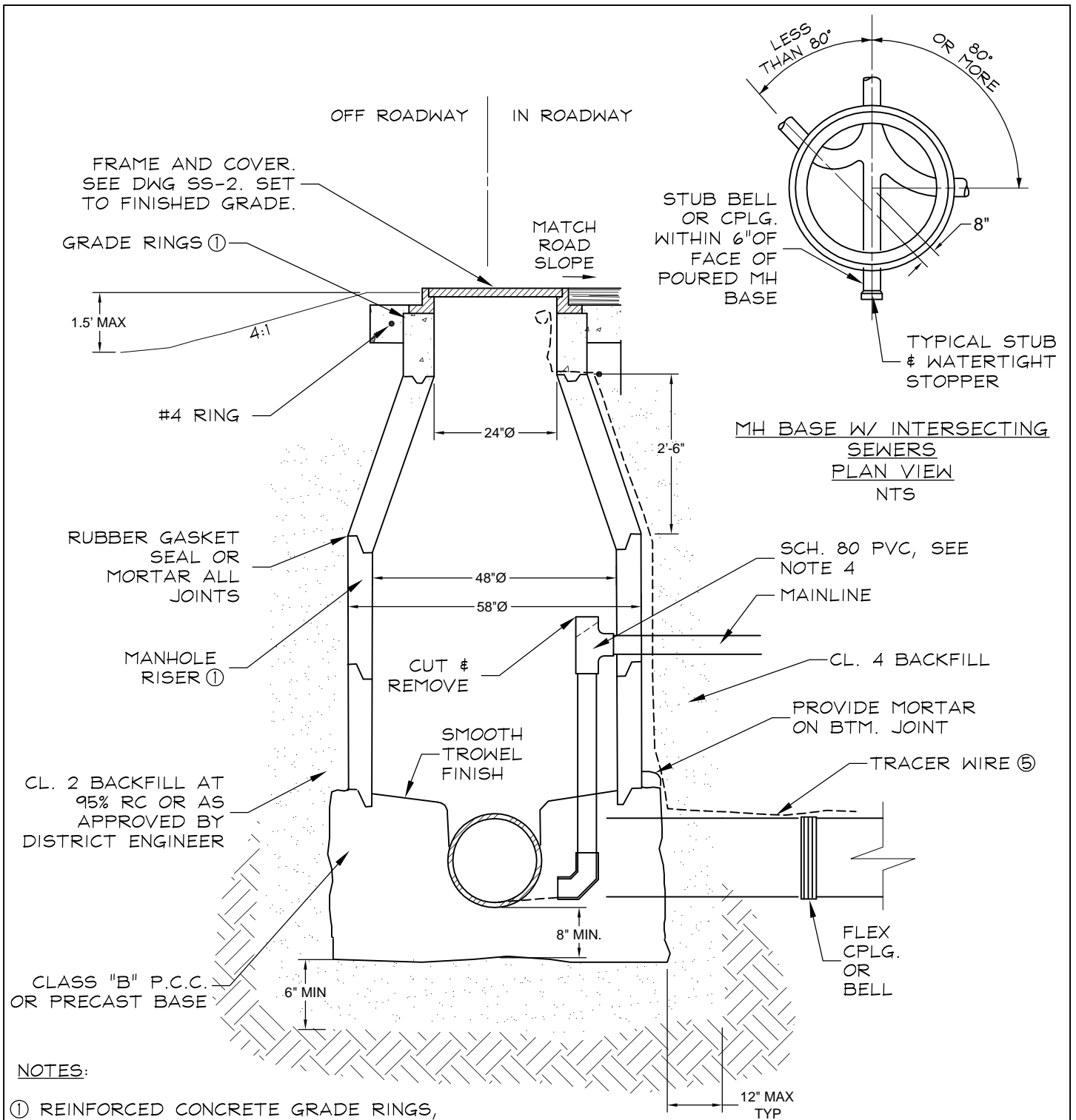

NOTES:

- ① REINFORCED CONCRETE GRADE RINGS, CONES, PIPE RISERS AND APPROVED PRECAST MANHOLE SECTIONS SHALL CONFORM TO CURRENT A.S.T.M. SPEC. No. C-478.
- ② USE CONCRETE COLLAR IN ROADWAY.
- ③ ALL INLETS AND OUTLETS FROM MANHOLE STRUCTURES SHALL HAVE A FLEXIBLE JOINT WITHIN 2' OF THE STRUCTURE.
- ④ ANCHOR TO MANHOLE W/ 2" STAINLESS STEEL BANDS AND ANCHORS, 24" O.C. (2 BANDS MIN)
- ⑤ TRACER WIRE SHALL BE TERMINATED BY GOING UP THE OUTSIDE OF THE MANHOLE TO THE LAST GRADE RING JOINT AND LEAVING 12" MIN INSIDE MANHOLE.

SANITARY SEWER MANHOLE				
DRAWN BY: MSO	SCALE: N.T.S.	DRAWING NO.:		
APPROVED: GSG	DATE: JULY 2013	SS-1		
REV No.:	DATE:			BY:
1	9/23/14			MSO

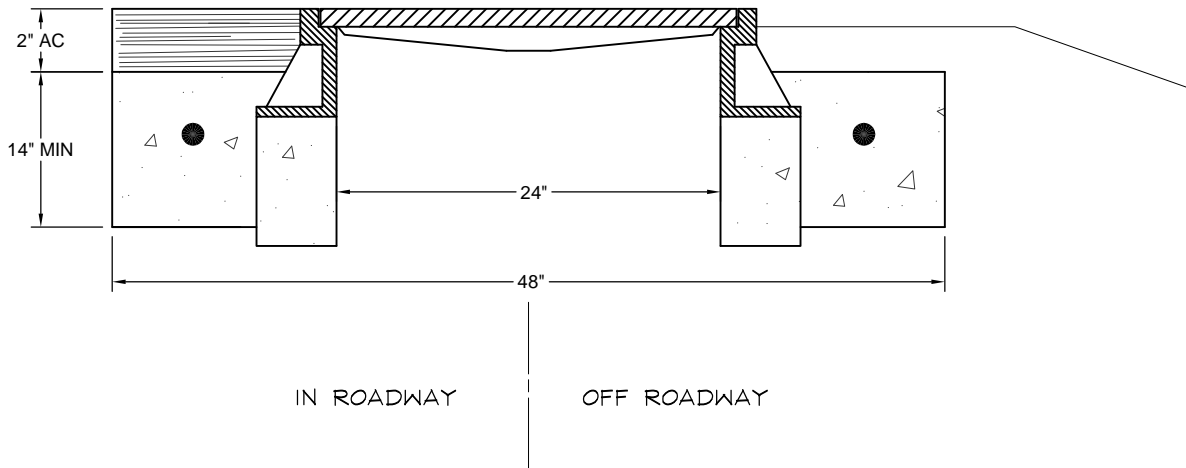
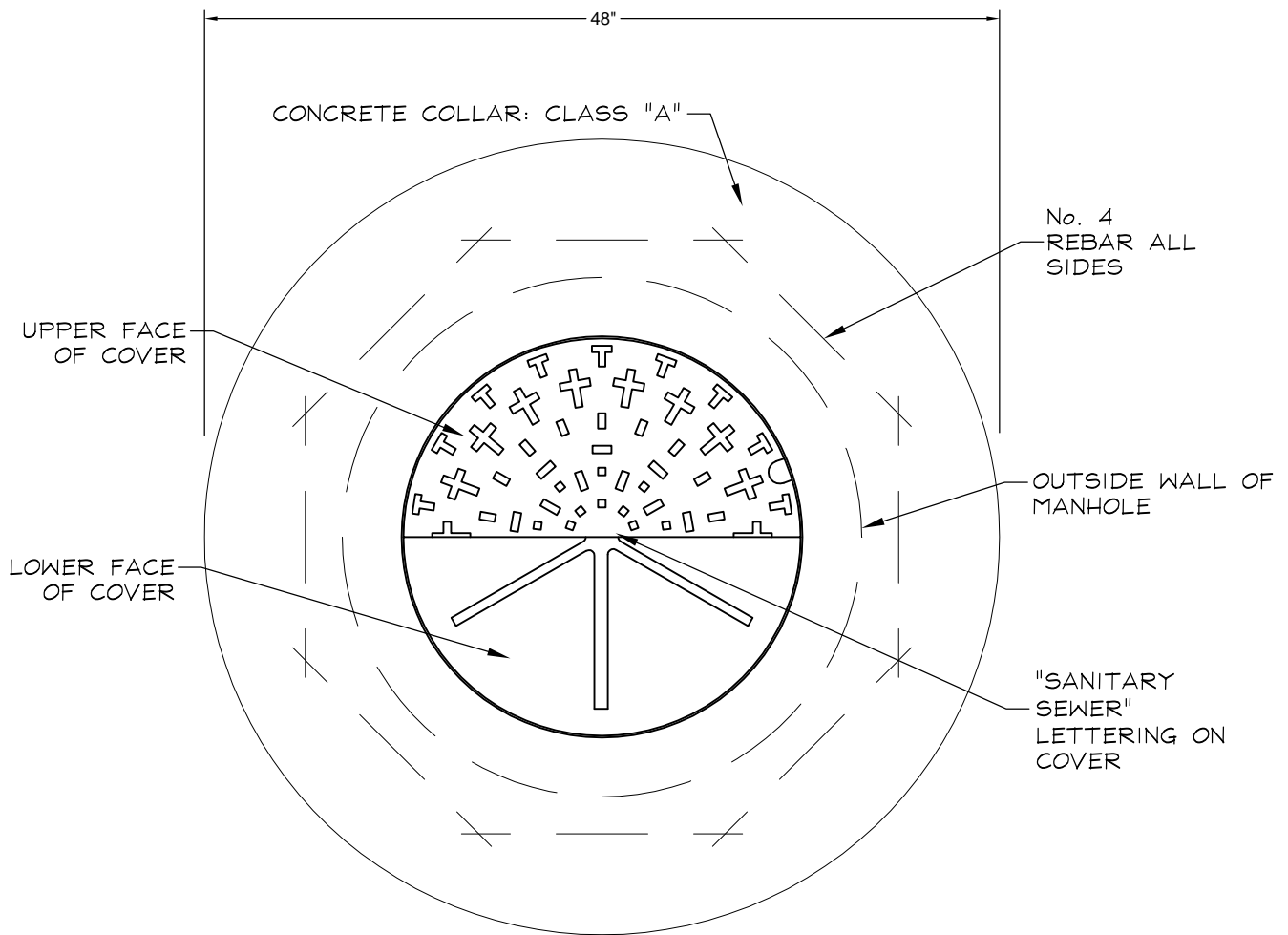

NOTES:

1. STANDARD MANHOLE FRAME AND COVER SHALL
2. ALL CONTACT SURFACES TO BE MACHINED.
3. A HIGH STRENGTH TRAFFIC COVER MAY BE REQUIRED IN AREAS AS DETERMINED BY DISTRICT ENGINEER.

SANITARY SEWER MANHOLE COVER

DRAWN BY:	MSO	SCALE:	N.T.S.
APPROVED:	GSG	DATE:	JULY 2013
REV No.:	DATE:	BY:	
1	8/27/14	MSO	

DRAWING NO.:
SS-2



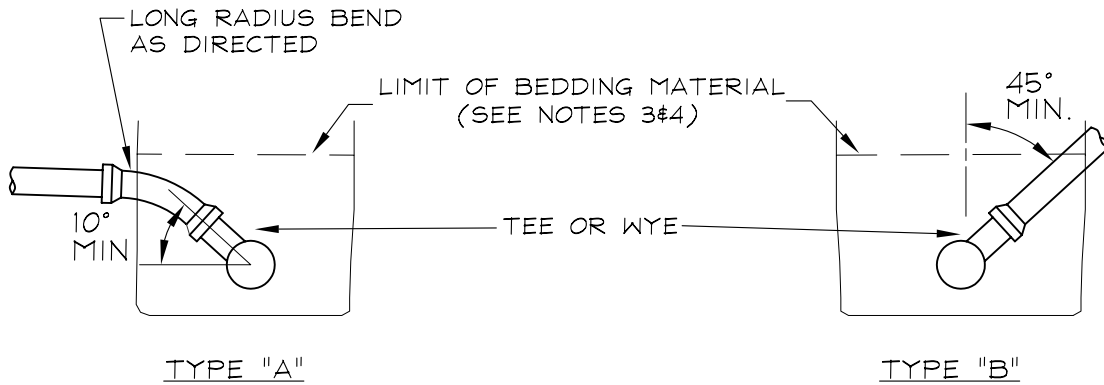
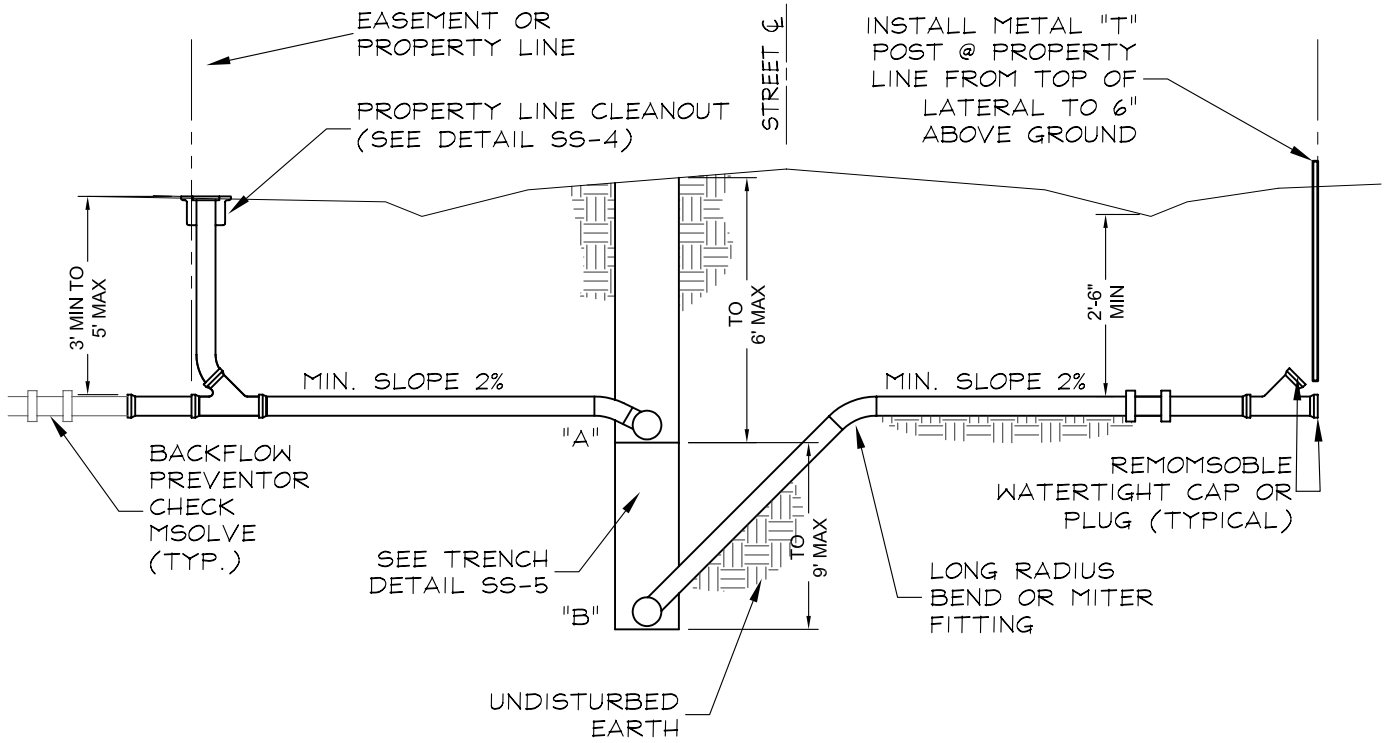

CONNECTION DETAILS

NOTES:

1. ALL SERVICE LINES SHALL BE 4" INSIDE DIA. UNLESS OTHERWISE NOTED.
2. SERVICE SEWER SHALL HAVE MINIMUM 3' COVER AT PROPERTY LINE.
3. PLACE WELL COMPACTED BEDDING MATERIAL 18" WIDE UNDER THE TEE BRANCH, AS DIRECTED. WHEN BEDDING MATERIAL IS USED, PLACE ADDITIONAL BEDDING MATERIAL TO TOP OF BEND, THE FULL WIDTH OF THE TRENCH.
4. BEDDING MATERIAL SHALL BE CLASS 1 BACKFILL IN ACCORDANCE WITH DISTRICT STANDARDS.

SANITARY SEWER SERVICE LATERALS				
DRAWN BY: MSO	SCALE: N.T.S.	DRAWING NO.:		
APPROVED: GSG	DATE: JULY 2013	SS-3		
REV No.:	DATE:			BY:
				

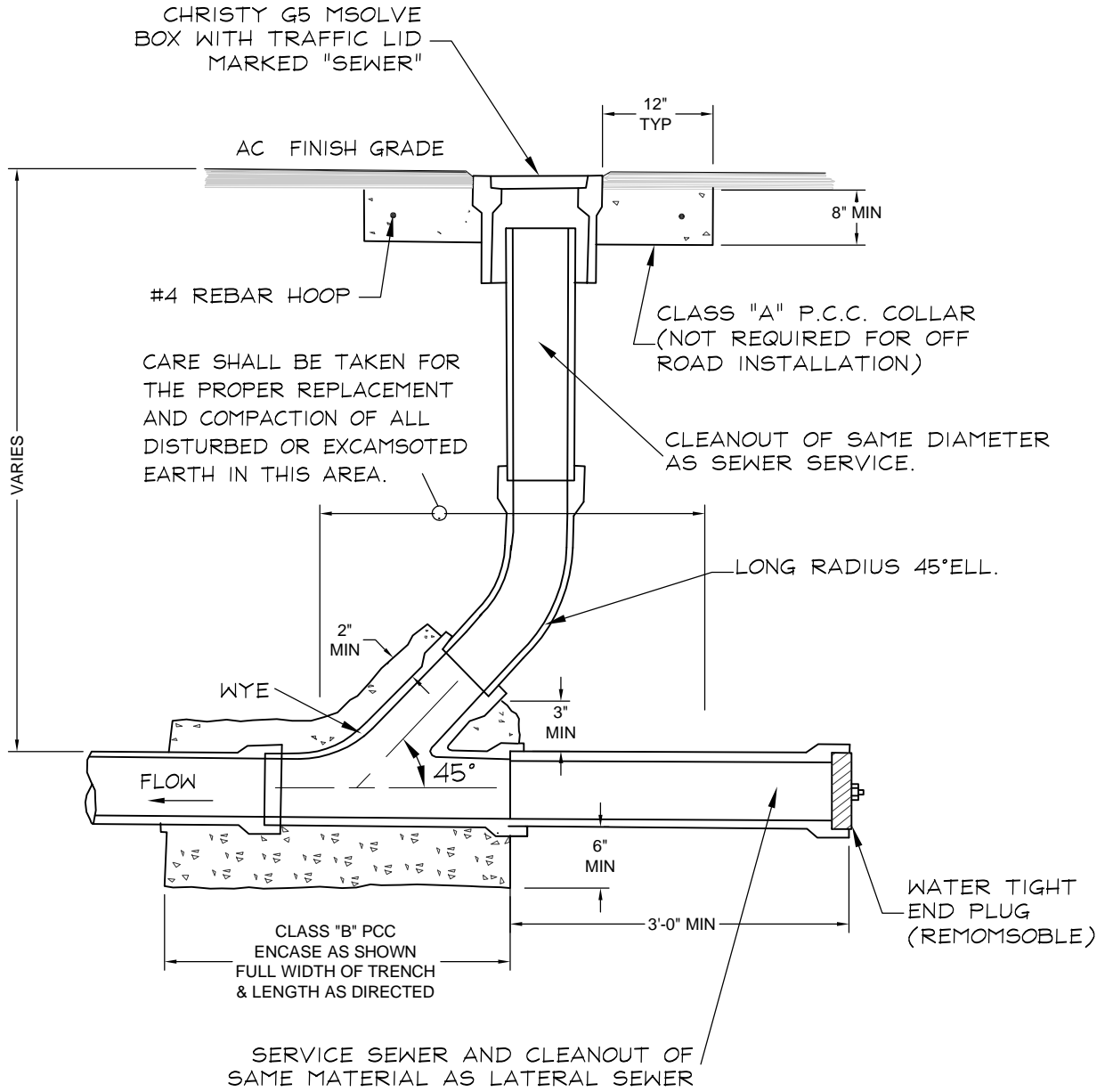

CLEANOUT BRANCH

DRAWN BY: MSO	SCALE: N.T.S.	DRAWING NO.:	
APPROVED: GSG	DATE: JULY 2013		
REV No.:	DATE:		BY:

SS-4



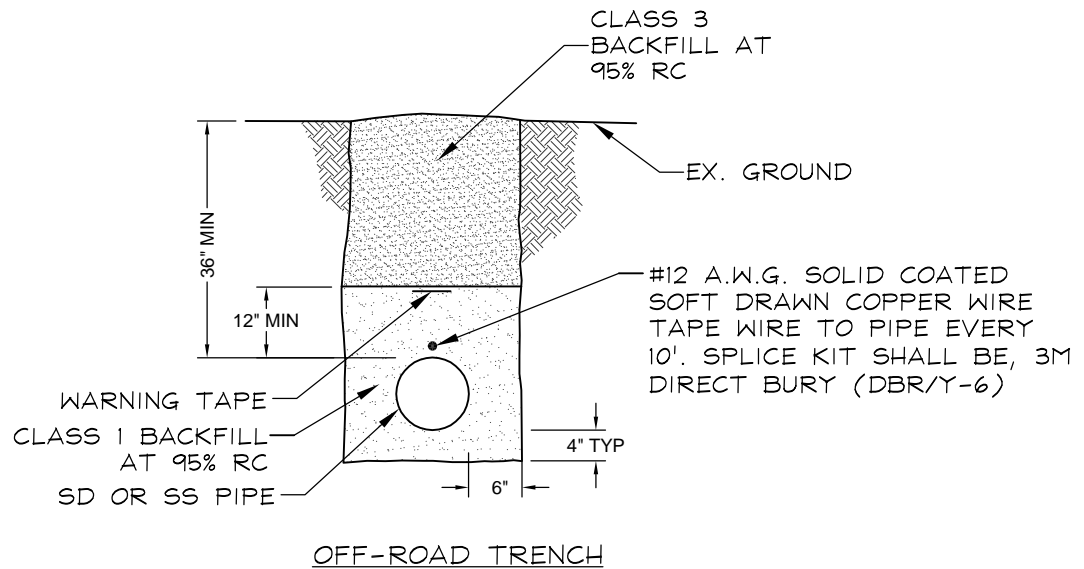
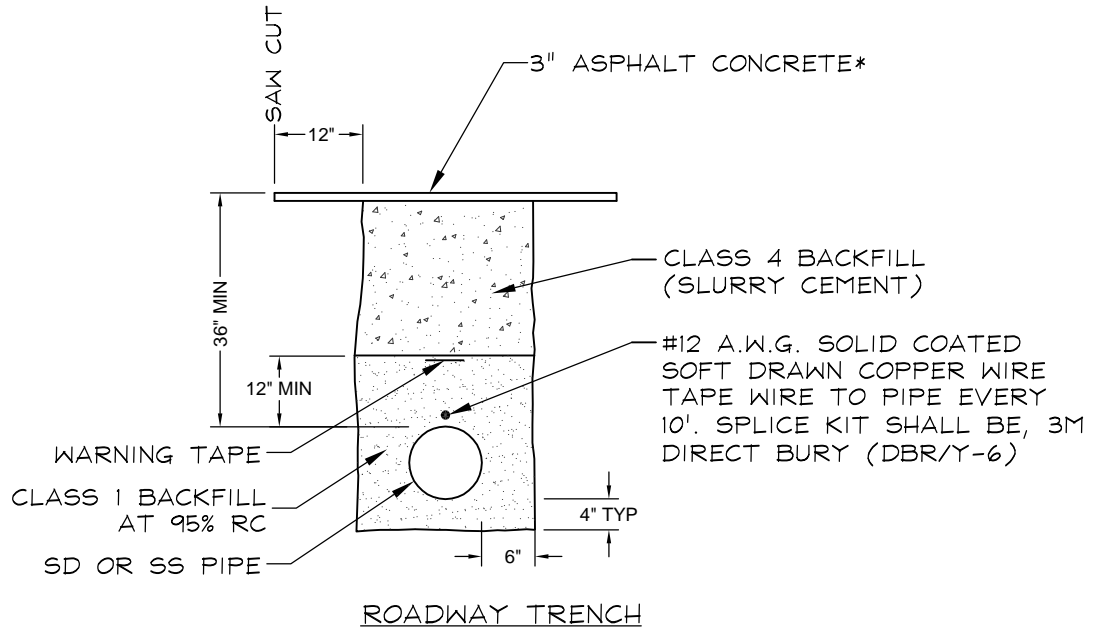

NOTES:

1. ALL EXCAVATION WITHIN THE RIGHT-OF-WAY SHALL BE BACKFILLED IN ACCORDANCE WITH SECTION 19-3 OF THE STATE STANDARD SPECIFICATIONS.
2. AREA ADJACENT TO THE TRENCH SHALL BE LEFT IN A CONDITION EQUAL TO OR BETTER THAN EXISTED PRIOR TO CONSTRUCTION.
3. SAW CUT EXISTING PAVEMENT BEFORE EXCAVATING.
4. PERCENT RELATIVE COMPACTION (RC) SHALL BE RELATIVE TO THE STANDARD LABORATORY CURVE DERIVED BY ASTM TEST METHOD D1557.
5. MAXIMUM TRENCH WIDTH SHALL BE 24" PLUS OUTSIDE DIAMETER OF PIPE, NO EXCEPTIONS.

* STRUCTURAL SECTION ELEMENTS MAY BE INCREASED WHERE REQUIRED BY THE DISTRICT ENGINEER DUE TO SOIL CONDITIONS AND/OR TRAFFIC CONSIDERATIONS. THE REPLACEMENT STRUCTURAL SECTION SHALL EQUAL THE EXISTING SECTION AS A MINIMUM REQUIREMENT IN GENERAL.

TRENCH DETAILS			
DRAWN BY:	MSO	SCALE:	N.T.S.
APPROVED:	GSG	DATE:	JULY 2013
REV No.:	DATE:	BY:	
DRAWING NO.:			SS-5
			

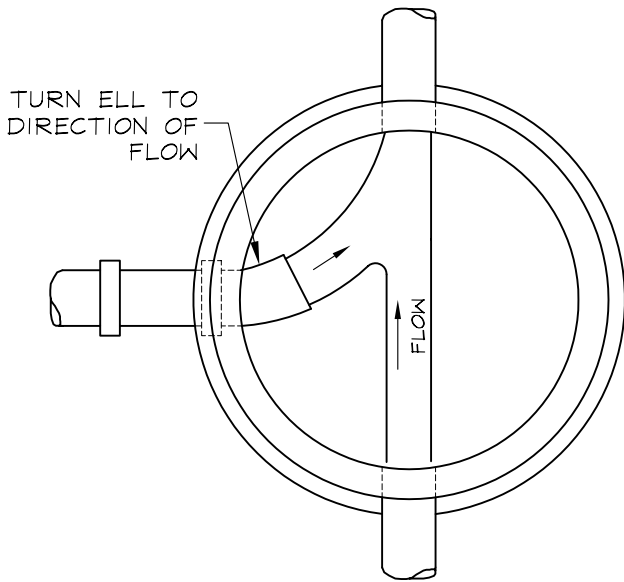

MANHOLE PLAN

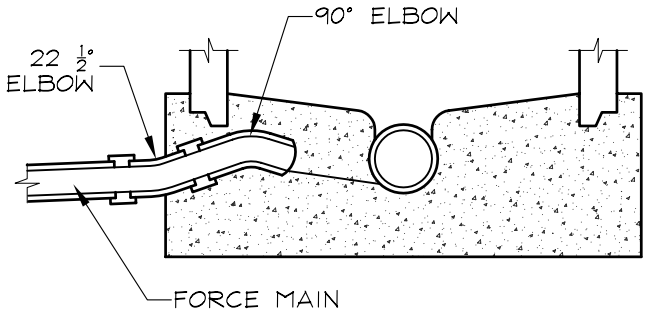

OUTLET CONNECTION @ MANHOLE SECTION

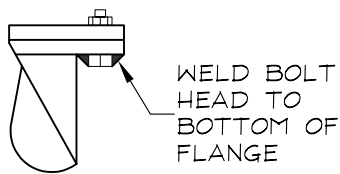

FLANGE DETAIL

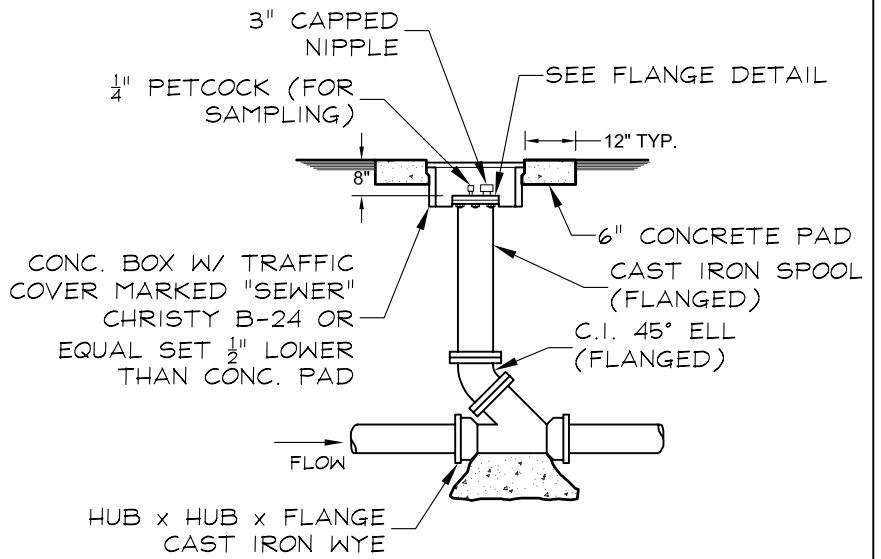

FLUSHING BRANCH ASSEMBLY

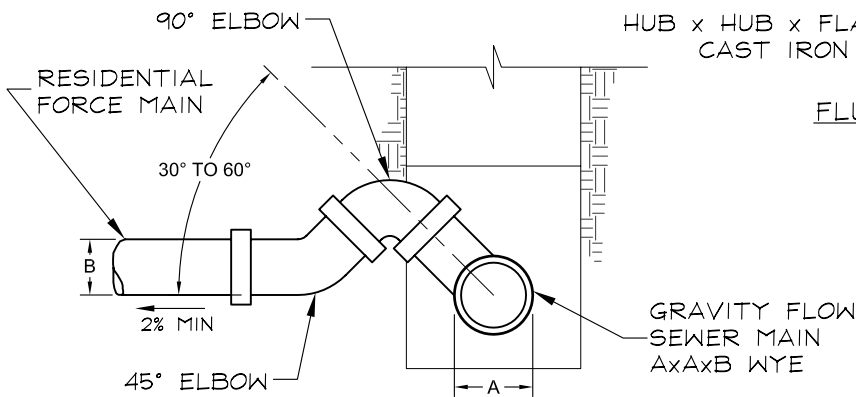

SERVICE LATERAL TO GRAVITY MAINLINE

NOTES:

1. PROVIDE SMOOTH TRANSITION BETWEEN INVERT OF INLET AND OUTLET PIPES.

STANDARD FORCE MAIN DETAILS

DRAWN BY: MSO	SCALE: N.T.S.	DRAWING NO.:	
APPROVED: GSG	DATE: JULY 2013	SS-6	
REV No.:	DATE:		BY:



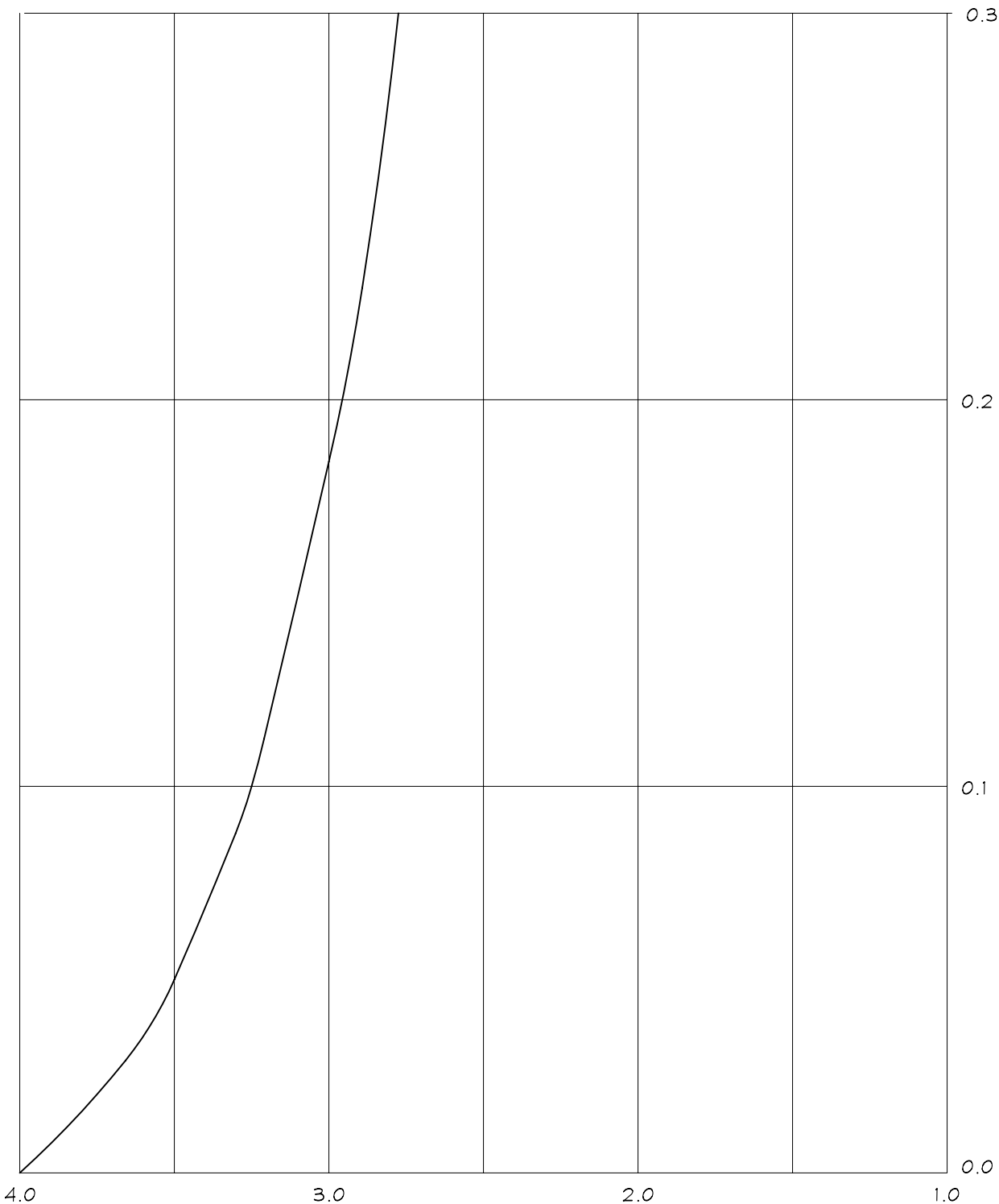

AVERAGE DAILY PROJECT FLOWS
 (M.G.D.)
 RESIDENTIAL SEWAGE PEAK FLOW
 FACTORS VS. AVERAGE DAILY FLOW

PEAKING FACTOR

PEAK FLOW FACTORS

DRAWN BY: MSO		SCALE: N.T.S.	
APPROVED: GSG		DATE: JULY 2013	
REV No.:	DATE:	BY:	

DRAWING NO.:

SS-7



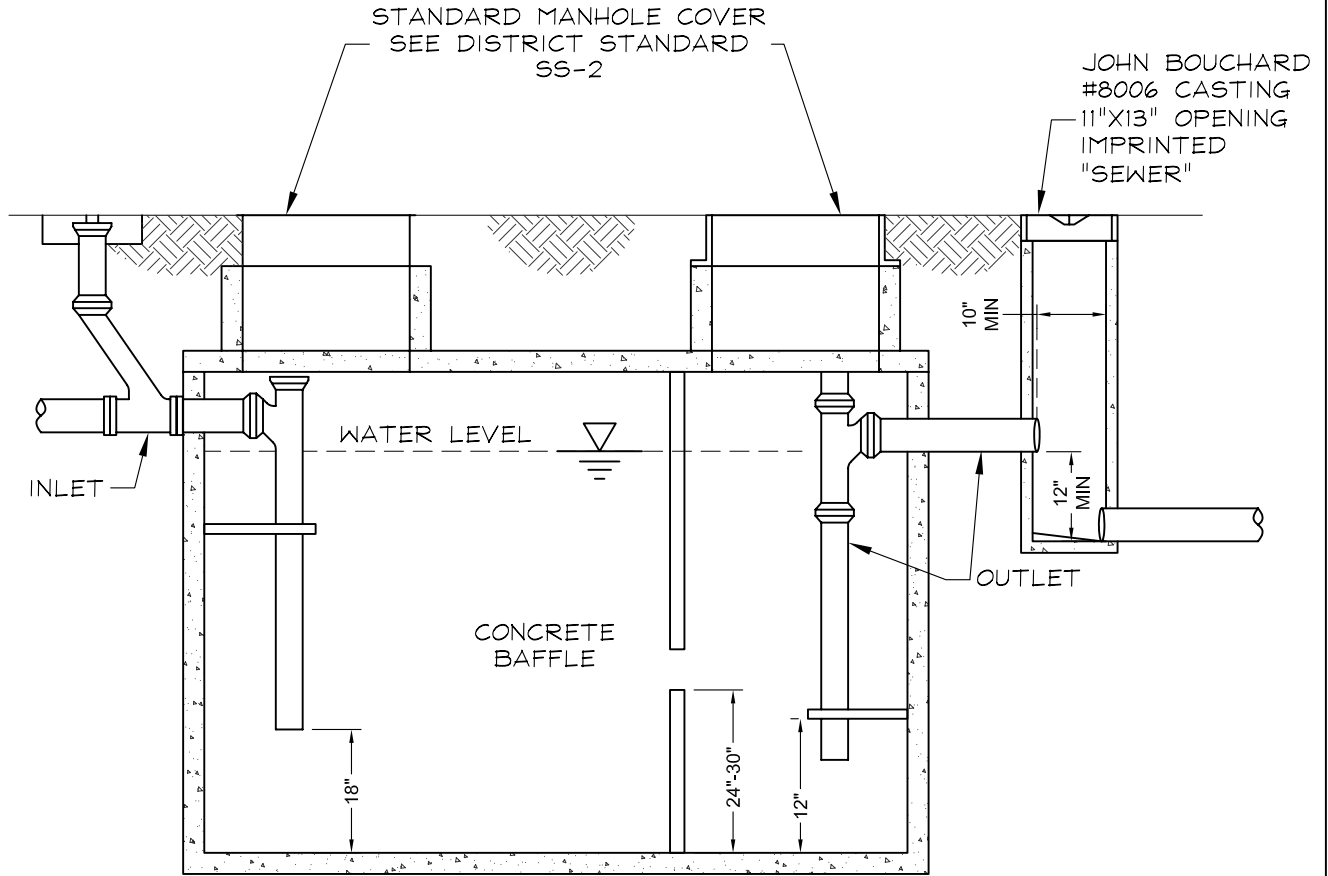

NOTES:

1. GREASE TRAP CAPACITY SHALL BE DETERMINED BY THE DISTRICT.
2. DRAWING IS SCHEMATIC. GREASE TRAP STRUCTURES SHALL BE DESIGNED BY QUALIFIED PROFESSIONAL FOR INDIVIDUAL PROJECTS.
3. DESIGN FOR H-20 LOADING WHERE LOCATED IN THE TRAVELED WAY.
4. ALL INLETS AND OUTLETS FROM GREASE TRAP STRUCTURES SHALL HAVE A FLEXIBLE JOINT WITHIN 2 FEET OF THE STRUCTURE.

GREASE TRAP WITH GREASE SAMPLING BOX			
DRAWN BY: MSO	SCALE: N.T.S.	DRAWING NO.:	SS-8
APPROVED: GSG	DATE: JULY 2013		
REV No.:	DATE:	BY:	



NOTES:

1. WIRE TO BE CONTINUOUS BETWEEN VALVE BOXES. A CONTINUITY TEST SHALL BE PERFORMED BY CONTRACTOR PRIOR TO FINAL ACCEPTANCE BY DISTRICT.
2. ALL FITTINGS TO BE WRAPPED W/ MINIMUM 6 MIL. POLYETHYLENE FILM

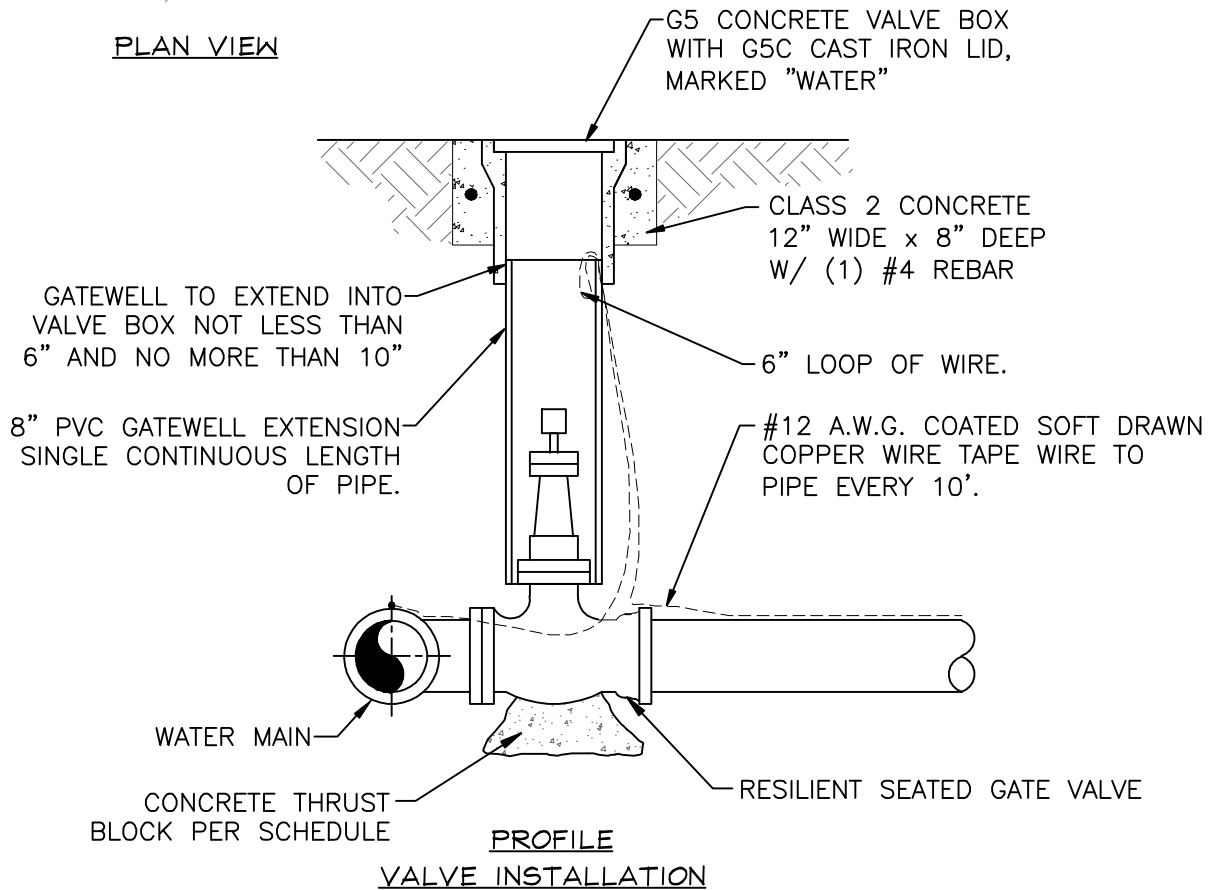
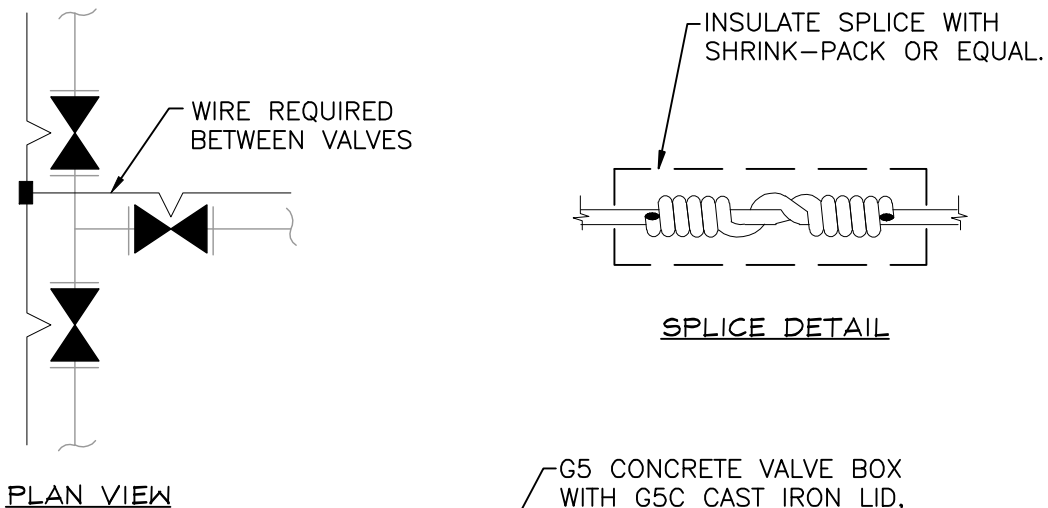

VALVE AND LOCATING WIRE INSTALLATION

DRAWN BY: MSO		SCALE: N.T.S.	DRAWING NO.: WS-1
APPROVED: GSG		DATE: JULY 2013	
REV No.:	DATE:	BY:	



NOTES:

1. PIPING FROM MAIN TO METER SHALL BE 1" POLYETHYLENE CTS WEST FLEX GOLD FOR ALL METER INSTALLATIONS.
2. ALL PIPE CONNECTIONS SHALL BE COMPRESSION TYPE: MUELLER "C-110"; FORD "PACK JOINT"; OR EQUAL.
3. SERVICE METER AND PIPE MUST NOT BE INSTALLED IN DRIVEWAY.
4. METER BOX SHALL BE CHRISTY N16 WITH CHRISTY B16G LID AND CHRISTY B16SL SLAB FOR 1" SERVICES. USE CHRISTY N36 BOX WITH B36G LID AND B36SL SLAB FOR 2" SERVICES. EQUAL BOXES, LIDS, AND SLABS MAY BE USED SUBJECT TO DISTRICT APPROVAL.
5. DUAL SERVICES SHALL NOT BE PERMITTED. VARIANCES TO METER LOCATION SHALL BE APPROVED BY DISTRICT ENGINEER.
6. BEDDING & BACKFILL REQUIRED ALONG SERVICE LINE PER STANDARD DETAIL WS-5.
7. FOR DOUBLE METER BOXES AT PROPERTY LINE SEE DETAIL THIS PAGE.
8. LOCATOR WIRE REQUIRED. SEE DETAIL WS-1.
9. THIS DETAIL APPLIES TO EXISTING RESIDENCES ONLY, FOR NEW CONSTRUCTION SEE DETAIL WS-2A FOR FIRE SPRINKLER CONNECTIONS.

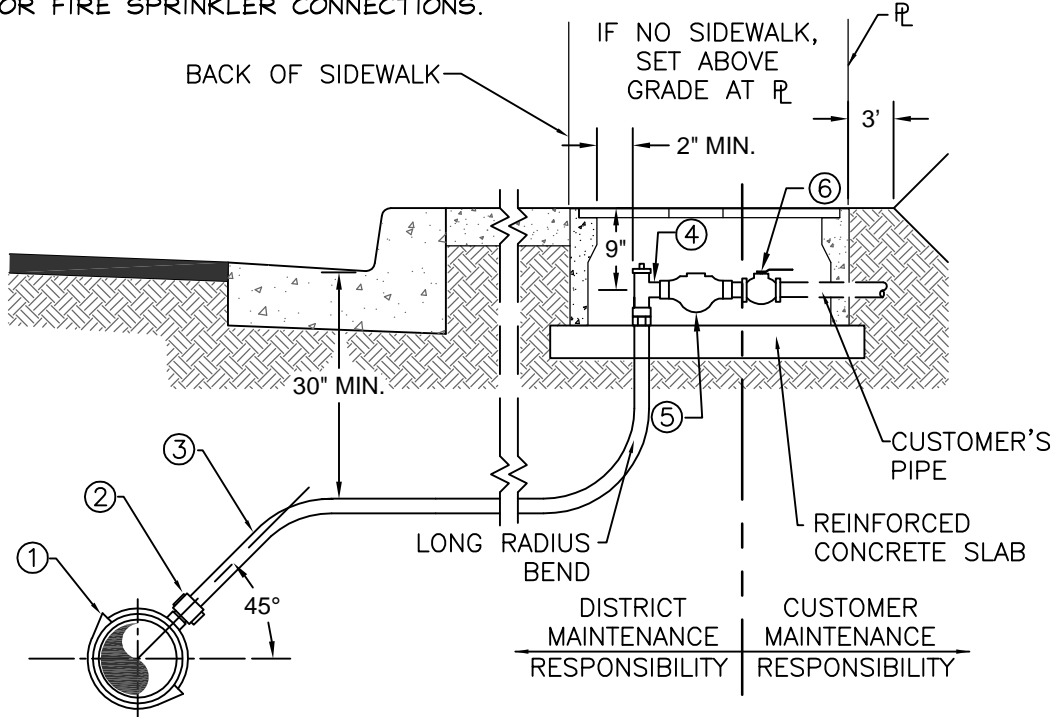

PROPERTY LINE SERVICE DETAIL

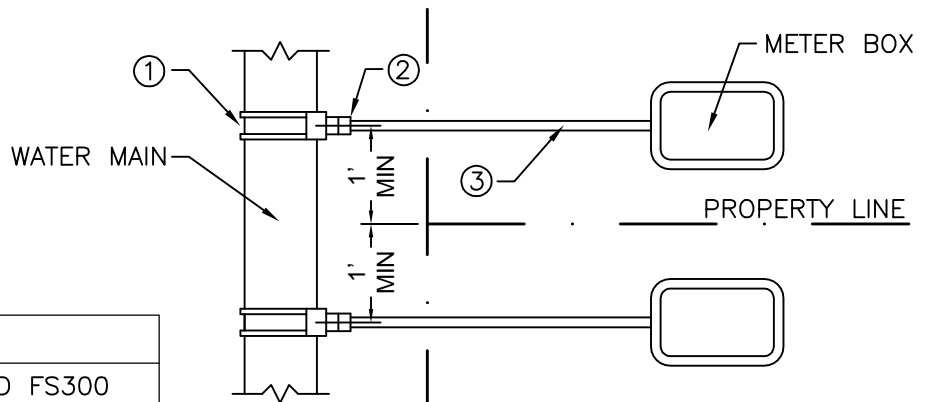

STANDARD SERVICE CONNECTION

ITEM	DESCRIPTION
1	SERVICE SADDLE – FORD FS300
2	CORPORATION STOP – FORD F1100
3	POLYETHYLENE CTS
4	ANGLED METER STOP – FORD KV43-342W
5	METER—SUPPLIED BY DISTRICT
6	BALL VALVE—CUSTOMER TO SUPPLY & INSTALL

DRAWN BY:	MSO	SCALE:	N.T.S.	DRAWING NO.:	WS-2
APPROVED:	GSG	DATE:	JULY 2013		
REV No.:	DATE:	BY:			
1	5/14/14	MSO			



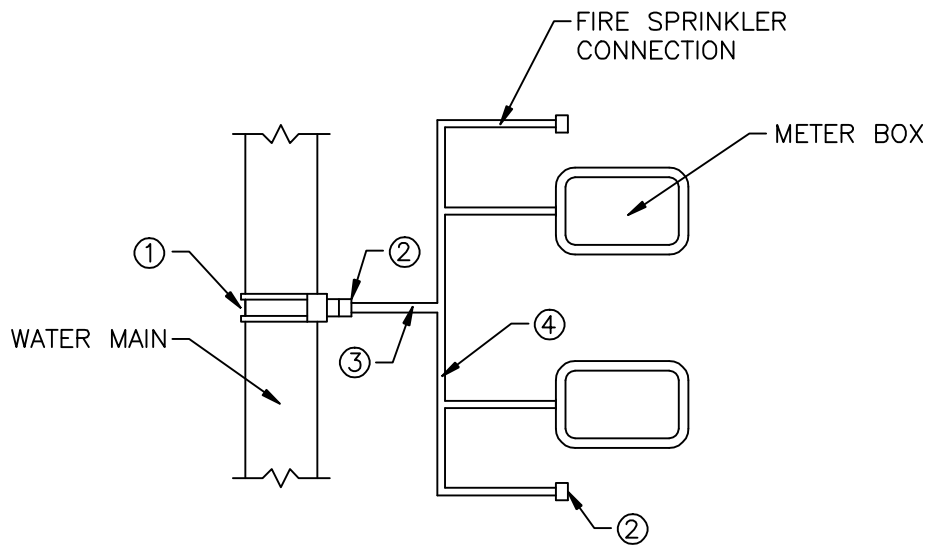

EXISTING SERVICES

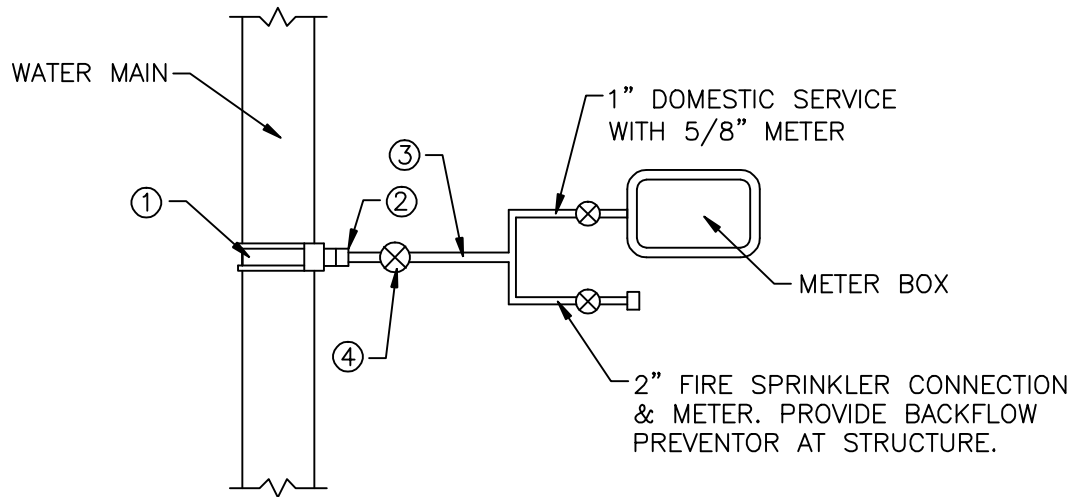

NEW CONSTRUCTION

FIRE SPRINKLER SERVICE CONNECTION

ITEM	DESCRIPTION
1	SERVICE SADDLE – FORD FS200
2	CORPORATION STOP – FORD F1100
3	2" SERVICE
4	2" IRON BODY GATE VALVE, W/ NUT

DRAWN BY:	MSO	SCALE:	N.T.S.	DRAWING NO.:
APPROVED:	GSG	DATE:	JULY 2013	
REV No.:	DATE:	BY:		

WS-2A



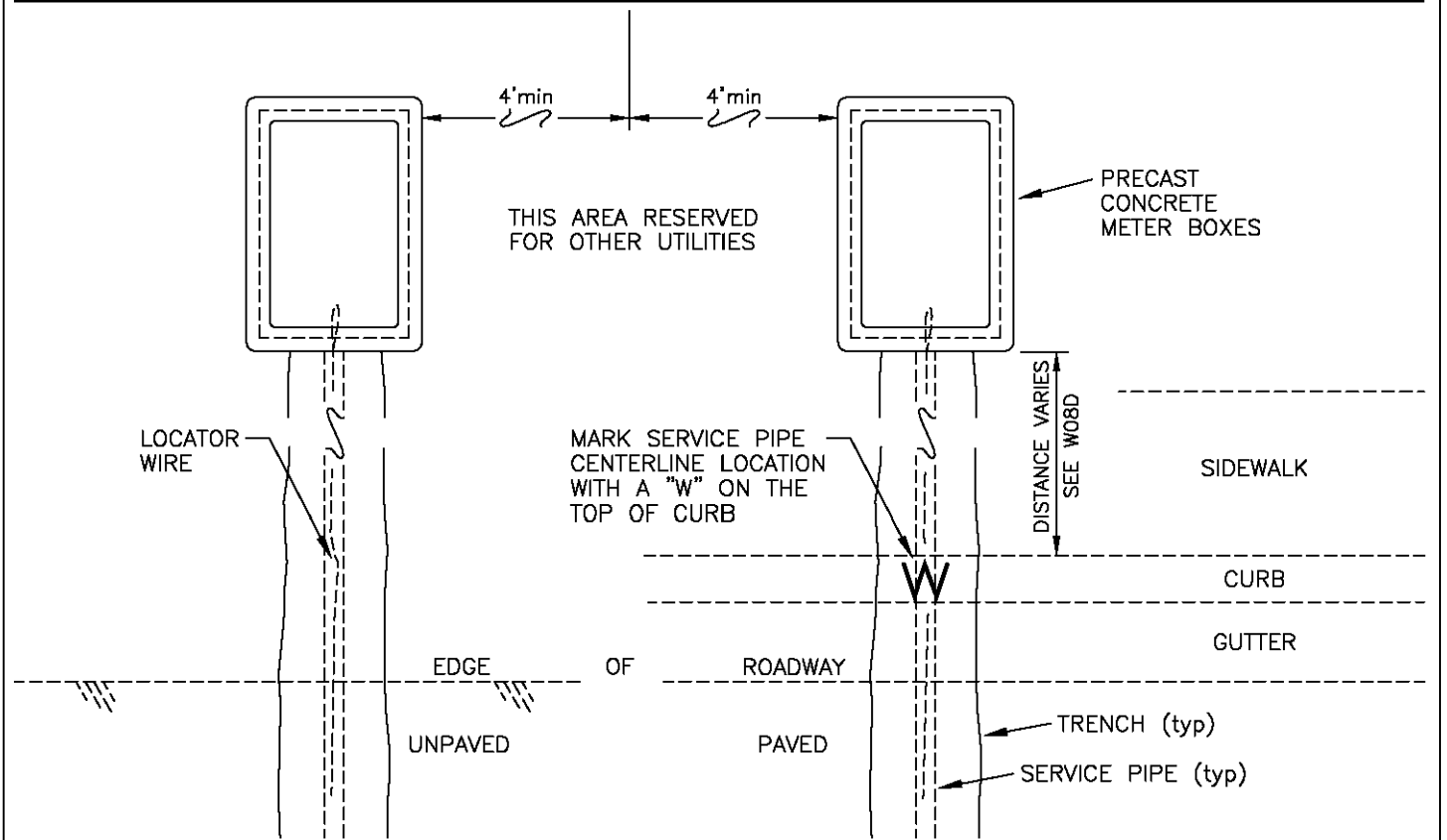
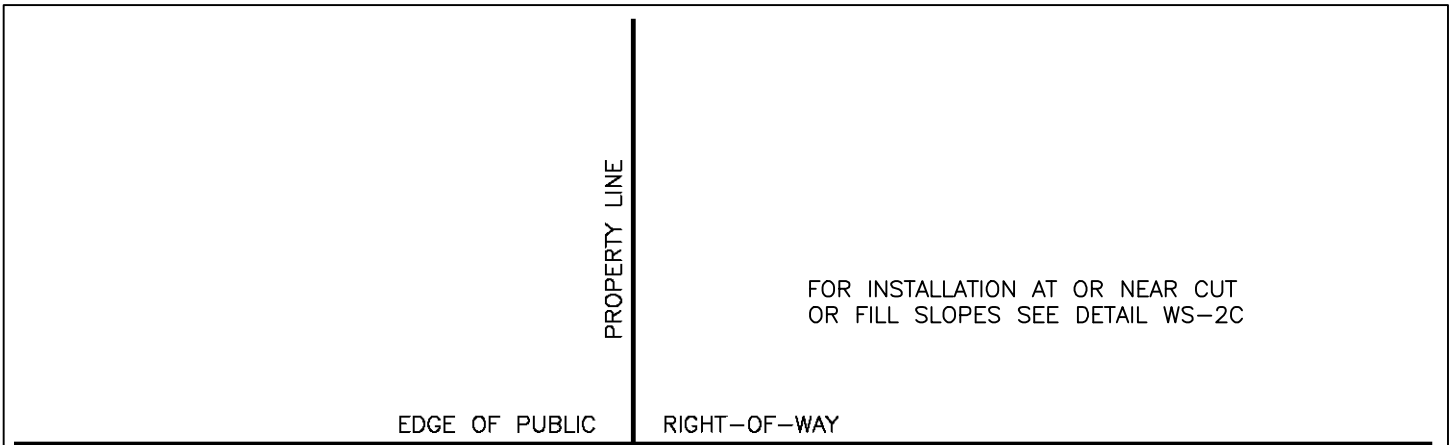

NOTES:

1. METER BOXES SHALL BE INSTALLED OUTSIDE OF PAVEMENT, DRIVEWAY OR SIDEWALK AND WITHIN EXISTING RIGHT OF WAY OR PUBLIC UTILITY EASEMENT.
2. FOR SERVICE & METER INSTALLATION SEE DETAIL WS-2
3. FOR INSTALLATION AT OR NEAR CUT/FILL SLOPES SEE DETAIL WS-2C
4. CUSTOMER RESPONSIBLE FOR INSTALLATION OF P.R.V. &/OR BACKFLOW DEVICE IF REQUIRED.

WATER METER BOX PLACEMENT-STANDARD			
DRAWN BY:	MSO	SCALE:	N.T.S.
APPROVED:	GSG	DATE:	JULY 2013
REV No.:	DATE:	BY:	
DRAWING NO.:			
WS-2B			

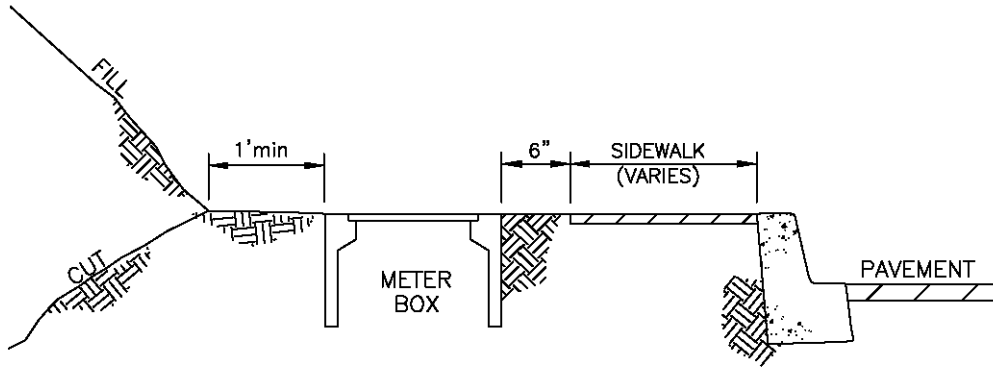

BEHIND SIDEWALK

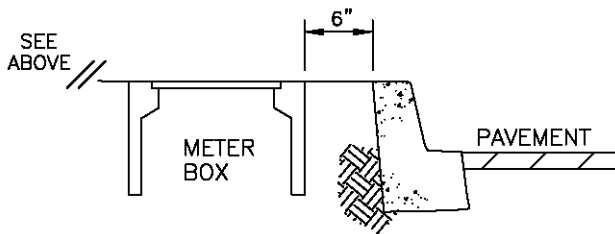

NO SIDEWALK

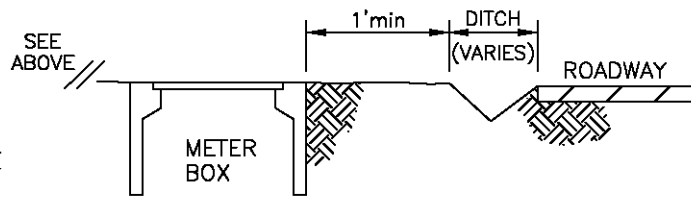

ROADSIDE DRAINAGE

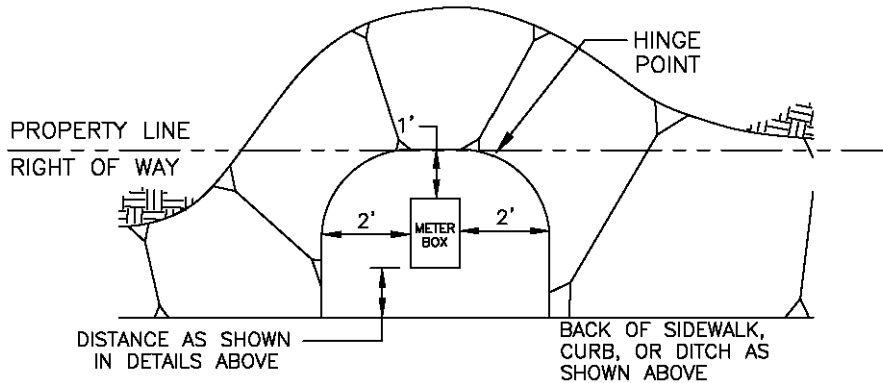

PLAN VIEW

NOTES:

1. METER BOXES ARE TO BE PLACED LENGTHWISE AS SHOWN.
2. FOR SERVICE & METER INSTALLATION SEE DETAIL WS-2
3. CUSTOMER RESPONSIBLE FOR INSTALLATION OF P.R.V. &/OR BACKFLOW DEVICE IF REQUIRED.

**WATER METER BOX
PLACEMENT-SLOPE**

DRAWN BY: MSO	SCALE: N.T.S.	DRAWING NO.:
APPROVED: GSG	DATE: JULY 2013	
REV No.:	DATE:	BY:

WS-2C



NOTES:

1. IN-LINE BLOW-OFF IS REQUIRED AT ALL LOW POINTS.
2. FOR MAINS 6" OR SMALLER, 2 INCH BLOW-OFF SHALL BE INSTALLED.
3. FOR MAINS 8" OR LARGER, 4 INCH BLOW-OFF SHALL BE INSTALLED.
4. THE TOP OF THE BOX SHALL BE FLUSH WITH PAVEMENT WHEN LOCATED IN TRAFFIC AREAS.
5. ALL BURIED NUTS AND BOLTS SHALL BE TYPE 316 STAINLESS STEEL.
6. LOCATOR WIRE PER DETAIL WS-1.

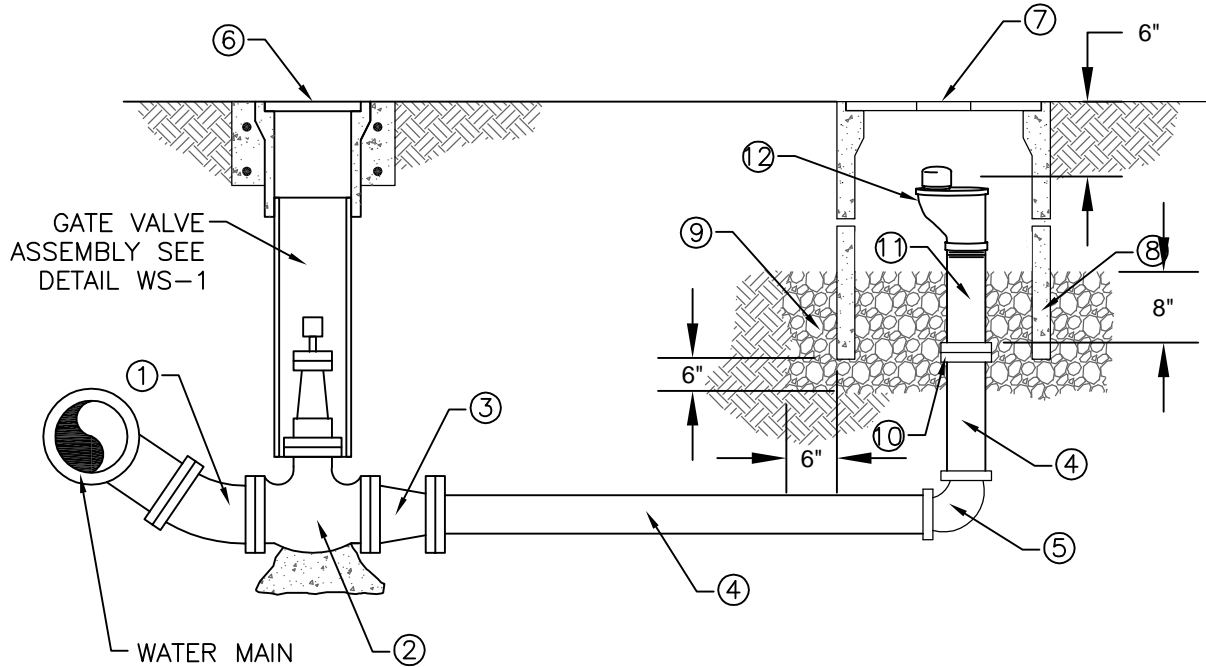

LEGEND:

- ① 45° BEND (DIP)
- ② GATE VALVE, 4" MIN.
- ③ REDUCER
- ④ 4" (DIP)
- ⑤ 4" (DIP) 90° BEND, "FIELD LOK" GASKETS
- ⑥ TRAFFIC VALVE BOX,
- ⑦ TRAFFIC BOX, CHRISTY NO. B1730 BOX (H-20 LOADING) WITH B1730-51JH STEEL CHECKER PLATE COVER
- ⑧ VALVE BOX EXTENSION, CHRISTY B1324x12 (H-20 LOADING)
- ⑨ 3/4" DRAIN ROCK, UP TO VALVE ONLY

2" BLOW-OFF

- ⑩ 4" COMPANION FLANGE W/ A 2" THREADED IP OUTLET
- ⑪ 2" BRASS NIPPLE, MIN OF 8" IN LENGTH
- ⑫ 2" BLOW-OFF/FLUSHING HYDRANT, TRUFLO MODEL TF500 MANUFACTURED BY KUPFERLE FOUNDRY CO.

4" BLOW-OFF

- ⑩ 4" COMPANION FLANGE W/ A 4" THREADED IP OUTLET
- ⑪ 4" BRASS NIPPLE, MIN OF 8" IN LENGTH
- ⑫ 4" BLOW-OFF/FLUSHING HYDRANT, TRUFLO MODEL TF800 MANUFACTURED BY KUPFERLE FOUNDRY CO.

IN-LINE BLOW-OFF ASSEMBLY

DRAWN BY: MSO		SCALE: N.T.S.	DRAWING NO.: WS-3
APPROVED: GSG		DATE: JULY 2013	
REV No.:	DATE:	BY:	



NOTES:

1. FOR MAINS 6" OR SMALLER, 2 INCH BLOW-OFF SHALL BE INSTALLED.
2. FOR MAINS 8" OR LARGER, 4 INCH BLOW-OFF SHALL BE INSTALLED.
3. THE TOP OF THE BOX SHALL BE FLUSH WITH PAVEMENT WHEN LOCATED IN TRAFFIC AREAS.
4. ALL BURIED NUTS AND BOLTS SHALL BE TYPE 316 STAINLESS STEEL.
5. GATE VALVE SIZE SHALL MATCH WATER MAIN SIZE.
6. LOCATOR WIRE PER DETAIL WS-1.

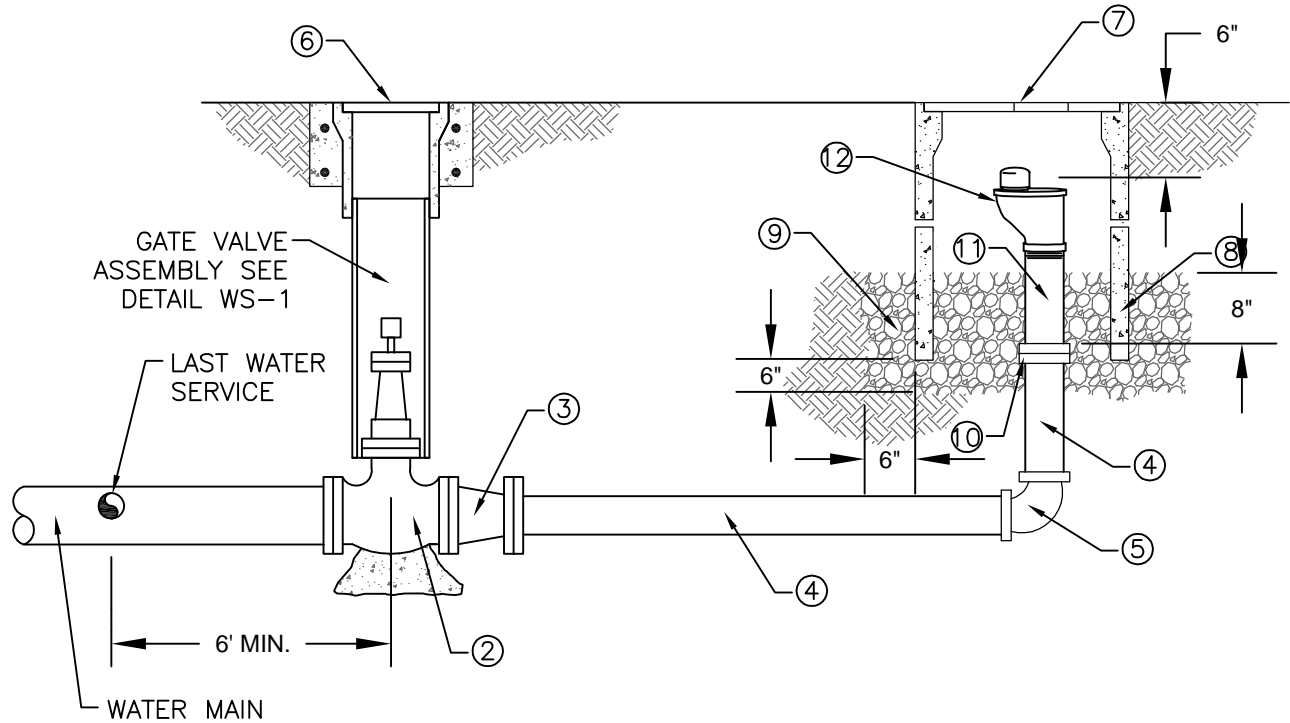

LEGEND:

- ① 45° BEND (DIP)
- ② GATE VALVE - MATCH MAIN SIZE
- ③ REDUCER
- ④ 4" (DIP)
- ⑤ 4" (DIP) 90° BEND, "FIELD LOK" GASKETS
- ⑥ TRAFFIC VALVE BOX PER WS-1
- ⑦ TRAFFIC BOX, CHRISTY NO. B1730 BOX (H-20 LOADING) WITH B1730-51JH STEEL CHECKER PLATE COVER
- ⑧ VALVE BOX EXTENSION, CHRISTY B1324x12 (H-20 LOADING)
- ⑨ 3/4" DRAIN ROCK, UP TO VALVE ONLY

2" BLOW-OFF

- ⑩ 4" COMPANION FLANGE W/ A 2" THREADED IP OUTLET
- ⑪ 2" BRASS NIPPLE, MIN OF 8" IN LENGTH
- ⑫ 2" BLOW-OFF/FLUSHING HYDRANT, TRUFLO MODEL TF500 MANUFACTURED BY KUPFERLE FOUNDRY CO.

4" BLOW-OFF

- ⑩ 4" COMPANION FLANGE W/ A 4" THREADED IP OUTLET
- ⑪ 4" BRASS NIPPLE, MIN OF 8" IN LENGTH
- ⑫ 4" BLOW-OFF/FLUSHING HYDRANT, TRUFLO MODEL TF800 MANUFACTURED BY KUPFERLE FOUNDRY CO.

DEAD END BLOW-OFF ASSEMBLY

DRAWN BY: MSO		SCALE: N.T.S.	DRAWING NO.: WS-4
APPROVED: GSG		DATE: JULY 2013	
REV No.:	DATE:	BY:	



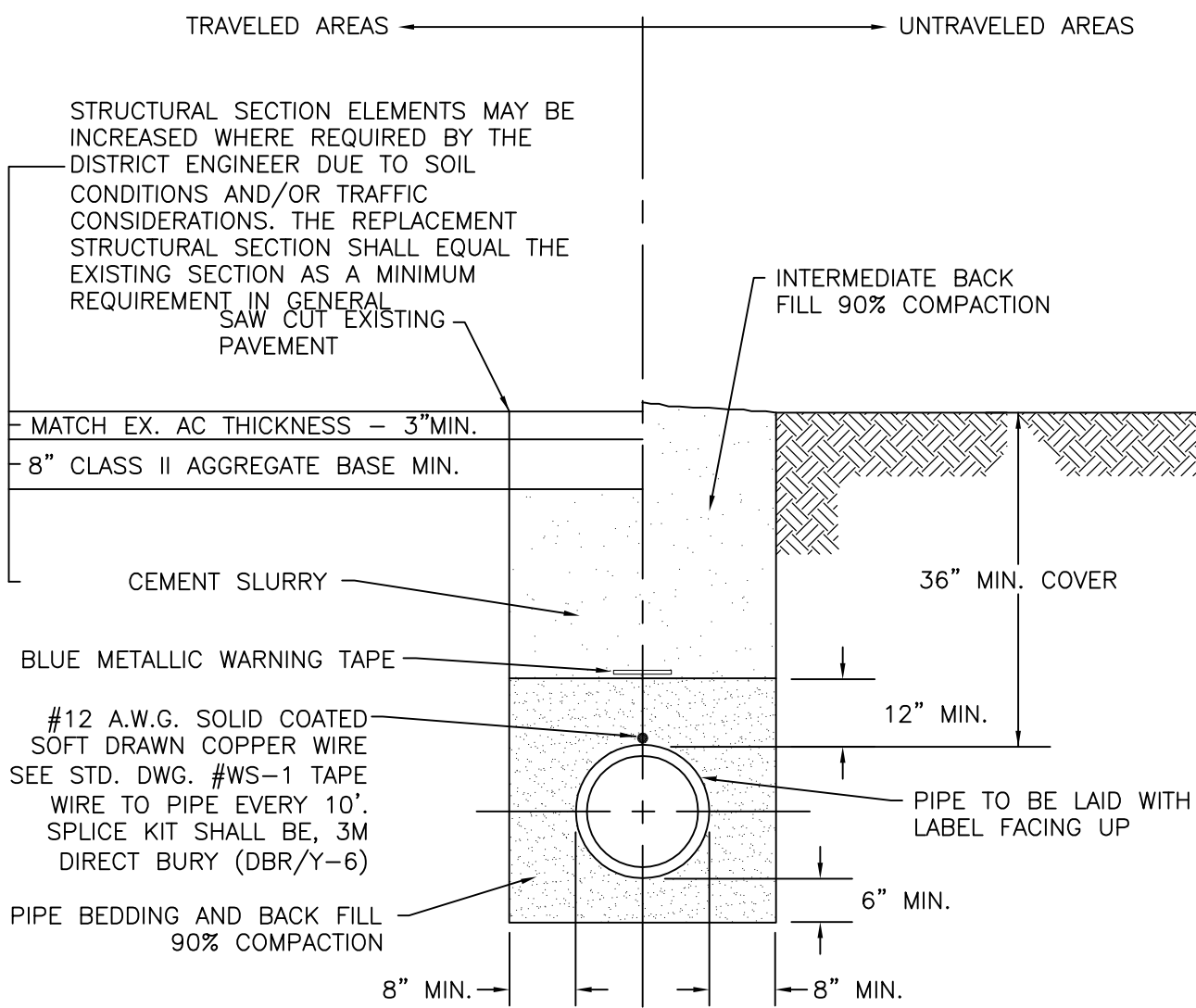

STRUCTURAL SECTION ELEMENTS MAY BE INCREASED WHERE REQUIRED BY THE DISTRICT ENGINEER DUE TO SOIL CONDITIONS AND/OR TRAFFIC CONSIDERATIONS. THE REPLACEMENT STRUCTURAL SECTION SHALL EQUAL THE EXISTING SECTION AS A MINIMUM REQUIREMENT IN GENERAL SAW CUT EXISTING PAVEMENT

- MATCH EX. AC THICKNESS - 3" MIN.
 - 8" CLASS II AGGREGATE BASE MIN.

CEMENT SLURRY

BLUE METALLIC WARNING TAPE

#12 A.W.G. SOLID COATED SOFT DRAWN COPPER WIRE SEE STD. DWG. #WS-1 TAPE WIRE TO PIPE EVERY 10'. SPLICE KIT SHALL BE, 3M DIRECT BURY (DBR/Y-6)

PIPE BEDDING AND BACK FILL 90% COMPACTION

INTERMEDIATE BACK FILL 90% COMPACTION

36" MIN. COVER

12" MIN.

PIPE TO BE LAID WITH LABEL FACING UP

6" MIN.

8" MIN.

8" MIN.

NOTES:

1. PIPE BEDDING SHALL COMPLY WITH DISTRICT IMPROVEMENT STANDARDS SECTION 15.05.
2. MINE TAILINGS ARE UN-ACCEPTABLE FOR ANY TRENCH BACKFILLING.
3. INTERMEDIATE BACKFILL SHALL BE IMPORTED OR NATIVE MATERIAL WITH ALL ROCKS OVER 3" REMOVED AND FREE OF VEGETATIVE MATERIAL. BACKFILL IN THE TRAVELED WAY SHALL BE CEMENT SLURRY.
4. PIPE COVER 40" OR GREATER MUST BE PRE-APPROVED BY DISTRICT ENGINEER
5. BLUE LOCATOR TAPE AT TOP OF SAND TO BE MARKED: "CAUTION - WATER LINE BURIED BELOW".

PIPE TRENCH BEDDING AND BACK FILL			
DRAWN BY:	MSO	SCALE:	N.T.S.
APPROVED:	GSG	DATE:	JULY 2013
REV No.:	DATE:	BY:	
DRAWING NO.:			<div style="display: flex; justify-content: space-around; align-items: center;"> WS-5 </div>

NOTES:

1. CONTRACTOR TO SET FIRE HYDRANT TO CORRECT GRADE. HYDRANT LOCATION TO BE DETERMINED BY FIRE DEPARTMENT.
2. BOLLARDS REQUIRED PER DETAIL WS-7, UNLESS OTHERWISE APPROVED BY DISTRICT ENGINEER.
3. FIRE HYDRANTS MUST BE COVERED (BAGGED) UNTIL AVAILABLE FOR USE.
4. LOCATING WIRE AFTER VALVE BOX IS NOT REQUIRED IF HYDRANT LATERAL IS PERPENDICULAR TO THE MAIN AND LESS THAN 40' LONG.
5. DRY BARREL - CLOW MEDALION.
6. BLUE REFLECTOR SHALL BE PLACED IN THE CENTER OF THE DRIVING LANE ADJACENT TO THE HYDRANT FOR LOCATION PURPOSES.

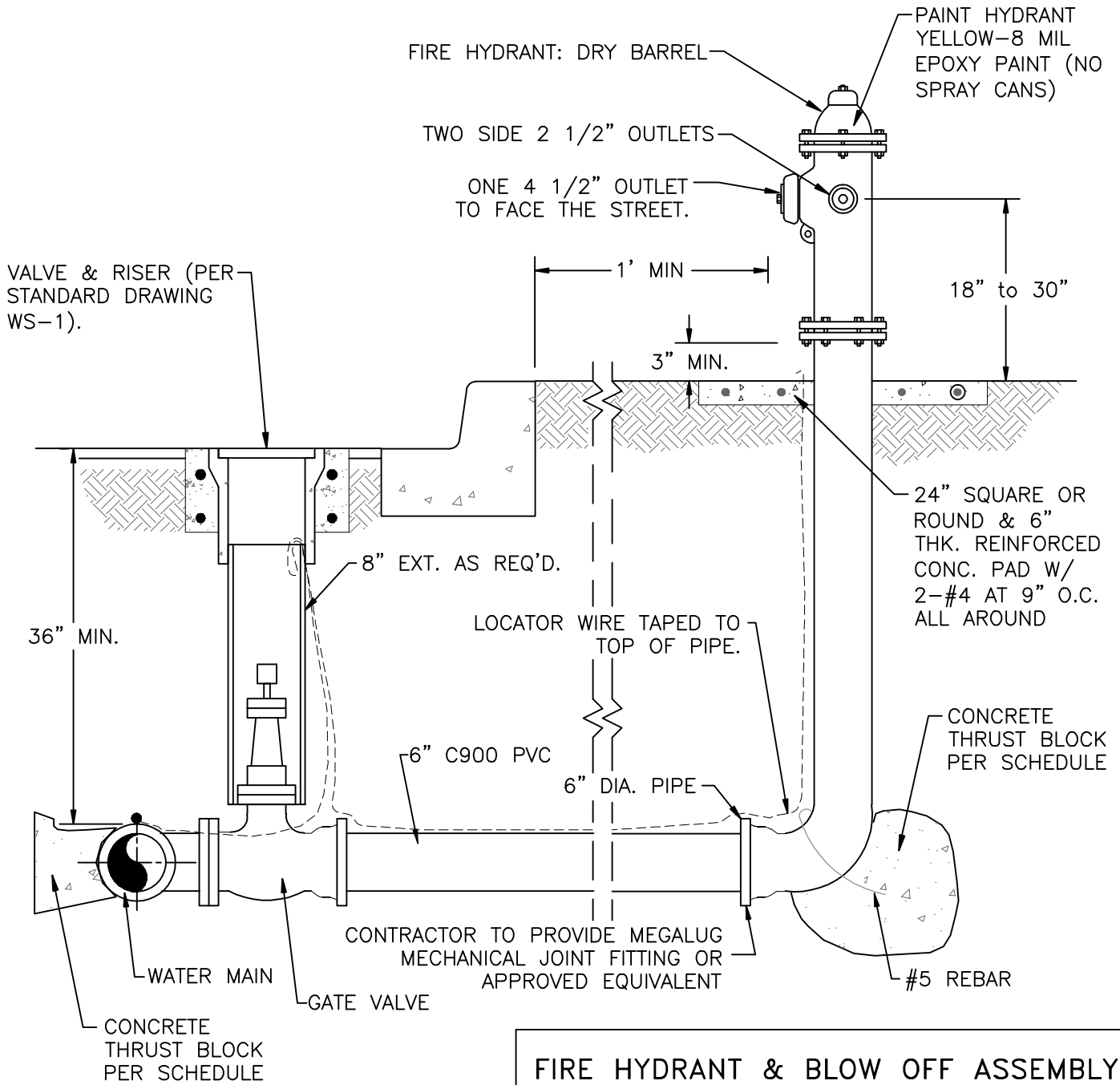

FIRE HYDRANT & BLOW OFF ASSEMBLY			
DRAWN BY: MSO	SCALE: N.T.S.	DRAWING NO.:	
APPROVED: GSG	DATE: JULY 2013	WS-6	
REV. No.:	DATE:		

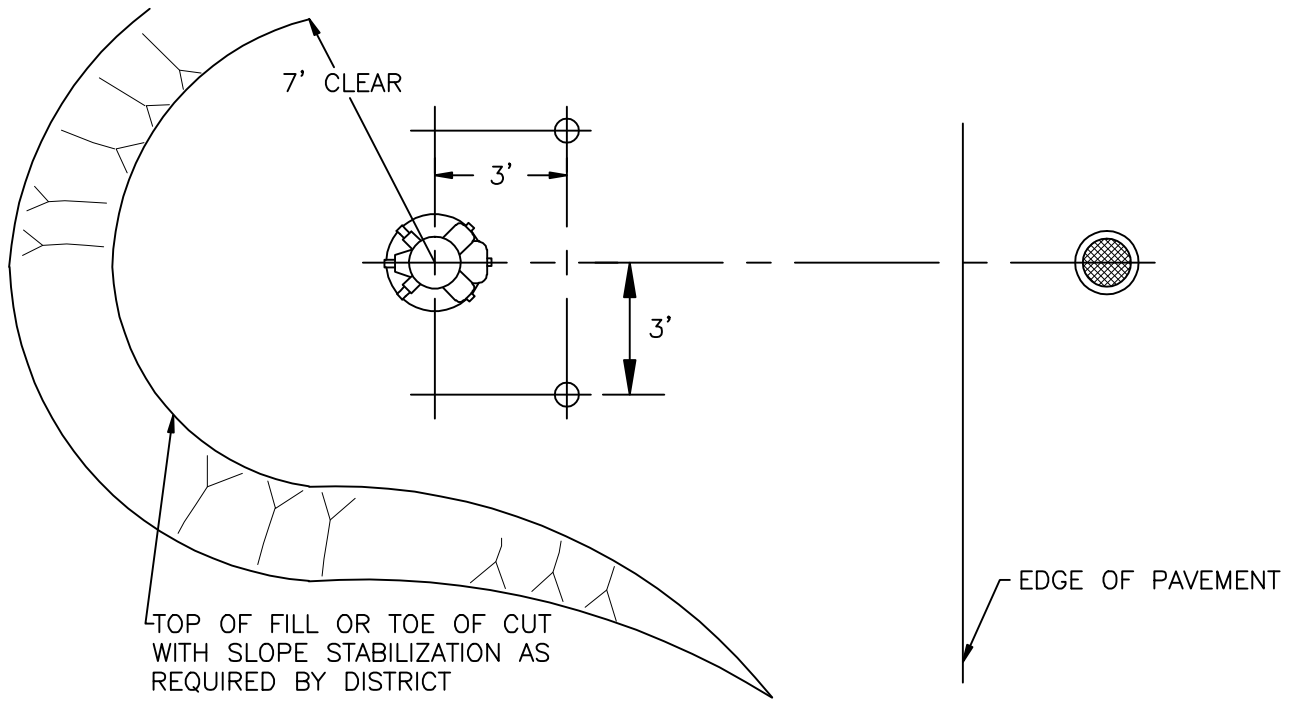

PLAN

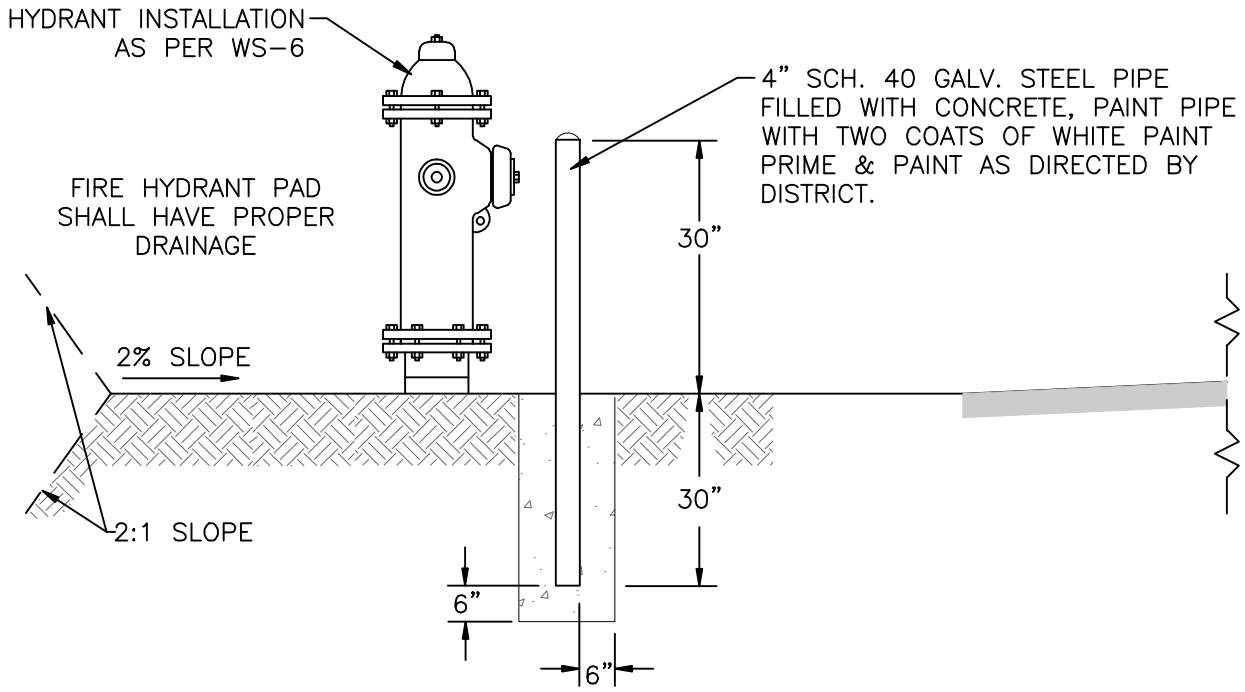

PROFILE

NOTES:

1. TWO BOLLARDS ARE REQUIRED UNLESS OTHERWISE APPROVED BY DISTRICT ENGINEER.
2. HYDRANT PAD SHALL BE CONSTRUCTED TO DRAIN AND HAVE A MINIMUM 95% RELATIVE COMPACTION.

FIRE HYDRANT BOLLARDS

DRAWN BY: MSO	SCALE: N.T.S.	DRAWING NO.:
APPROVED: GSG	DATE: JULY 2013	
REV No.:	DATE:	BY:

WS-6A



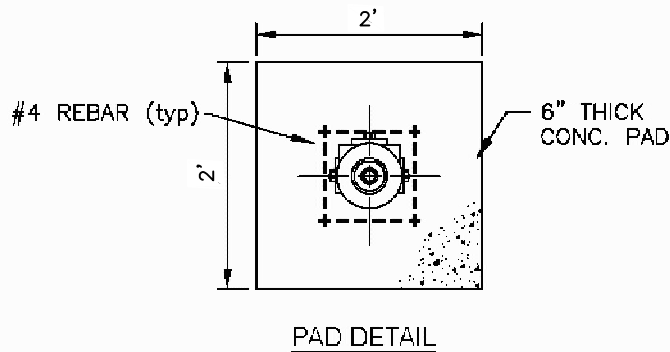
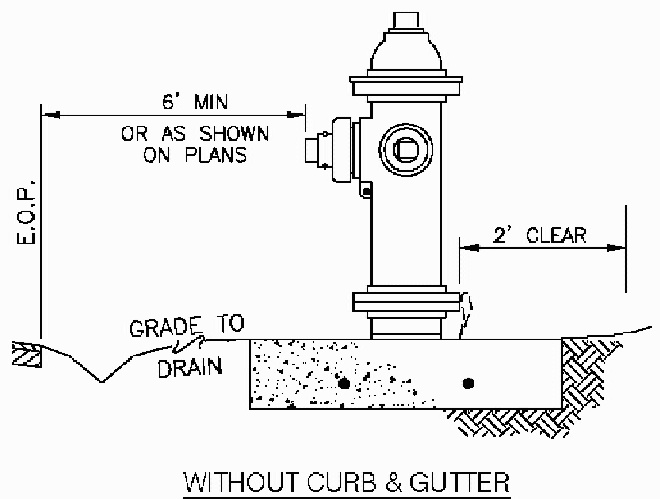
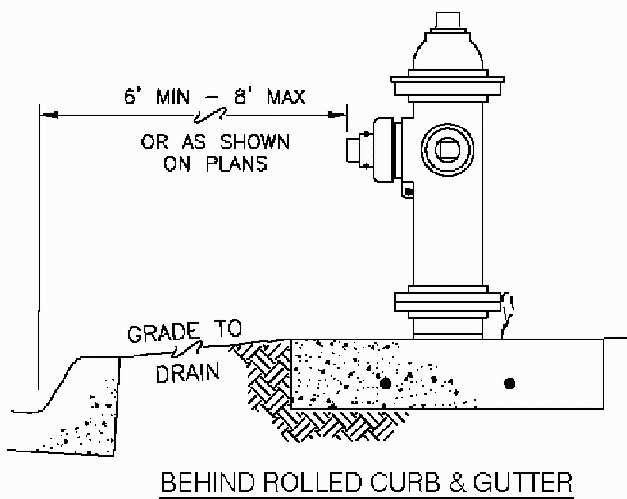
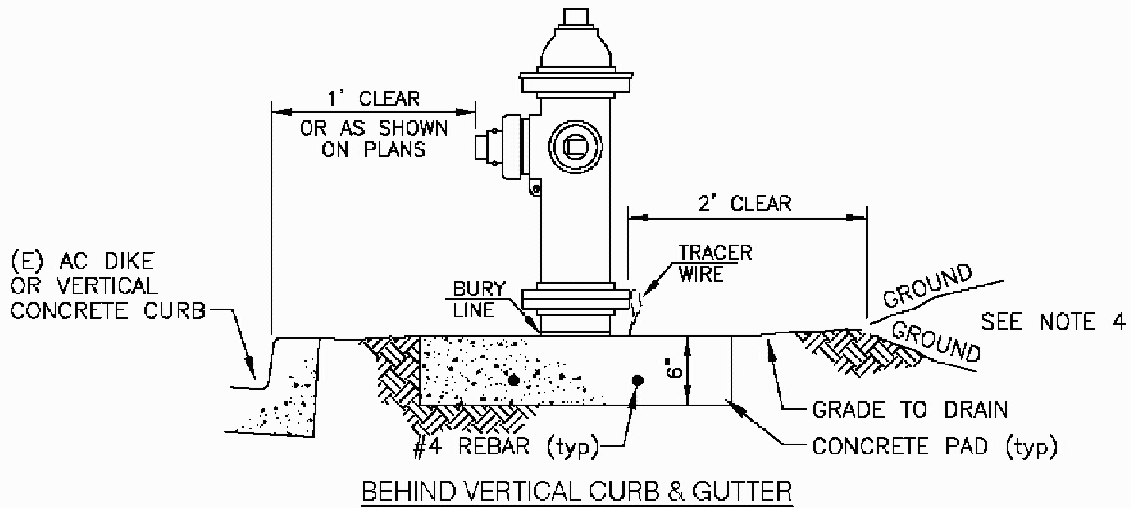

NOTES:

1. THE FIRE HYDRANT IS TO BE PLACED BEHIND THE DRAINAGE DITCH AND NO FURTHER THAN 8' (ft) FROM DRIVEABLE SHOULDER SURFACE, BACK OF CURB, OR PER AGENCY INVOLVED.
2. ALL VALVE BOXES SET IN THE AC OR CONCRETE TO BE FINISHED GRADE MINUS 1/4" (in).
3. FOR TYPICAL INSTALLATION SEE DETAIL WS-6
4. ALTERNATE LOCATIONS & SLOPES GREATER THAN 2:1 IN ANY INSTANCE MUST HAVE DISTRICT ENGINEER'S APPROVAL PRIOR TO INSTALLATION.

TYPICAL FIRE HYDRANT LOCATIONS

DRAWN BY: MSO	SCALE: N.T.S.	DRAWING NO.:
APPROVED: GSG	DATE: JULY 2013	
REV No.:	DATE:	BY:

WS-6B



NOTES:

1. THIS DETAIL IS INTENDED TO ILLUSTRATE A TYPICAL LAYOUT OF REQUIRED EQUIPMENT & CLEARANCES AND IS NOT INTENDED FOR CONSTRUCTION PURPOSES. DIFFERENT PIPE SIZES WILL REQUIRE DIFFERENT LAYOUTS. PRV STATION DESIGN IS SUBJECT TO DISTRICT APPROVAL.
2. PIT SUMP SHALL DRAIN TO DAYLIGHT THROUGH A 4" DIA. DRAIN PIPE OR HAVE SOME OTHER POSITIVE MEANS OF DRAINAGE SUCH AS A SUMP PUMP OR EDUCTOR.
3. INLINE VALVES SHALL BE LOCATED WITHIN 20' OF THE PRV STATION.
4. ALL EXPOSED PIPE & FITTINGS SHALL BE COATED WITH 8 MIL. EPOXY PAINT.
5. VALVE SUPPORTS SHALL BE PLACED AS DIRECTED.
6. PRECAST CONCRETE VAULT SHALL BE APPROVED BY DISTRICT ENGINEER.

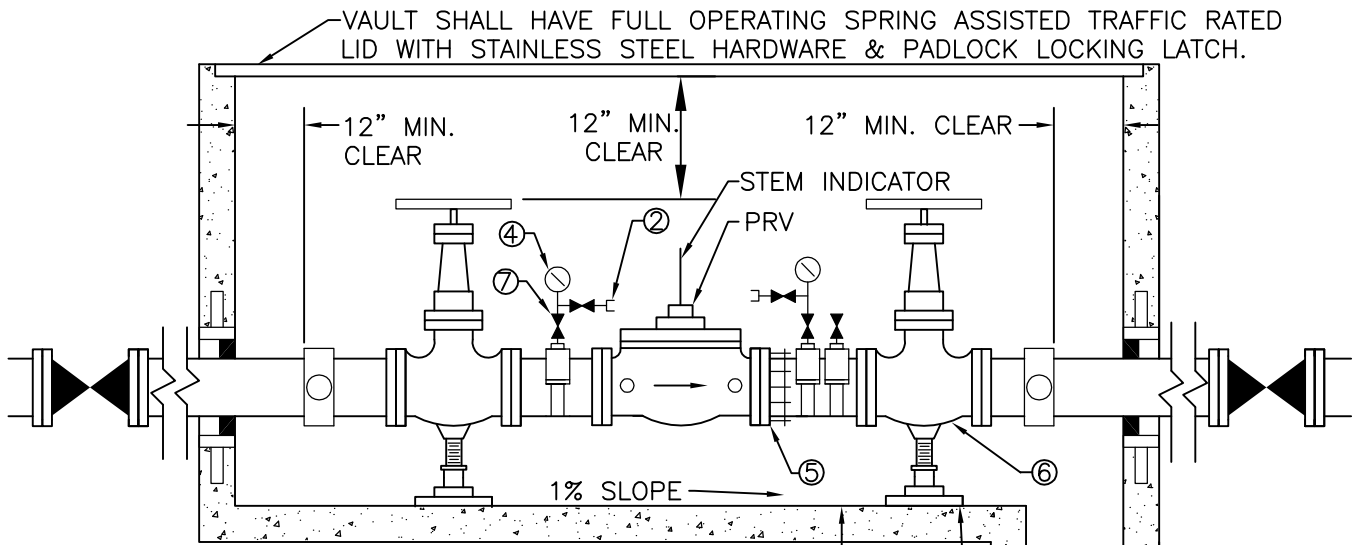
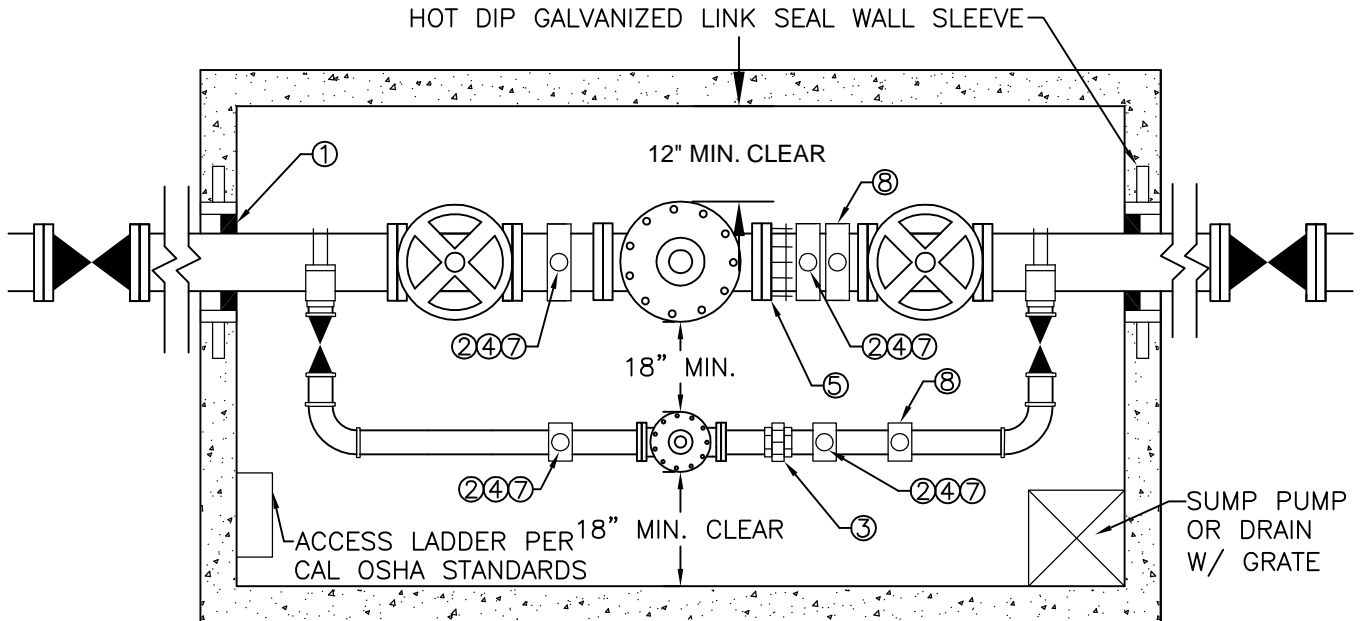

18" MIN. CLEAR
 ADJUSTABLE PIPE SUPPORT
 GROUDED & BOLTED TO PAD
 ANVIL INT'L #264 OR EQUAL.

ITEM	DESCRIPTION
1	WALL PENETRATION SEAL—THUNDER LINE LINK SEAL OR EQUAL.
2	1/2" HOSE BIB
3	UNION
4	PRESSURE INDICATOR
5	FLANGE COUPLING ADAPTER
6	HAND WHEEL OPERATED FLANGED GATE VALVE
7	BALL VALVE
8	2" SADDLE WITH GATE VALVE

PRESSURE REDUCING STATION LAYOUT

DRAWN BY: MSO	SCALE: N.T.S.	DRAWING NO.:	
APPROVED: GSG	DATE: JULY 2013	WS-7	
REV No.:	DATE:		

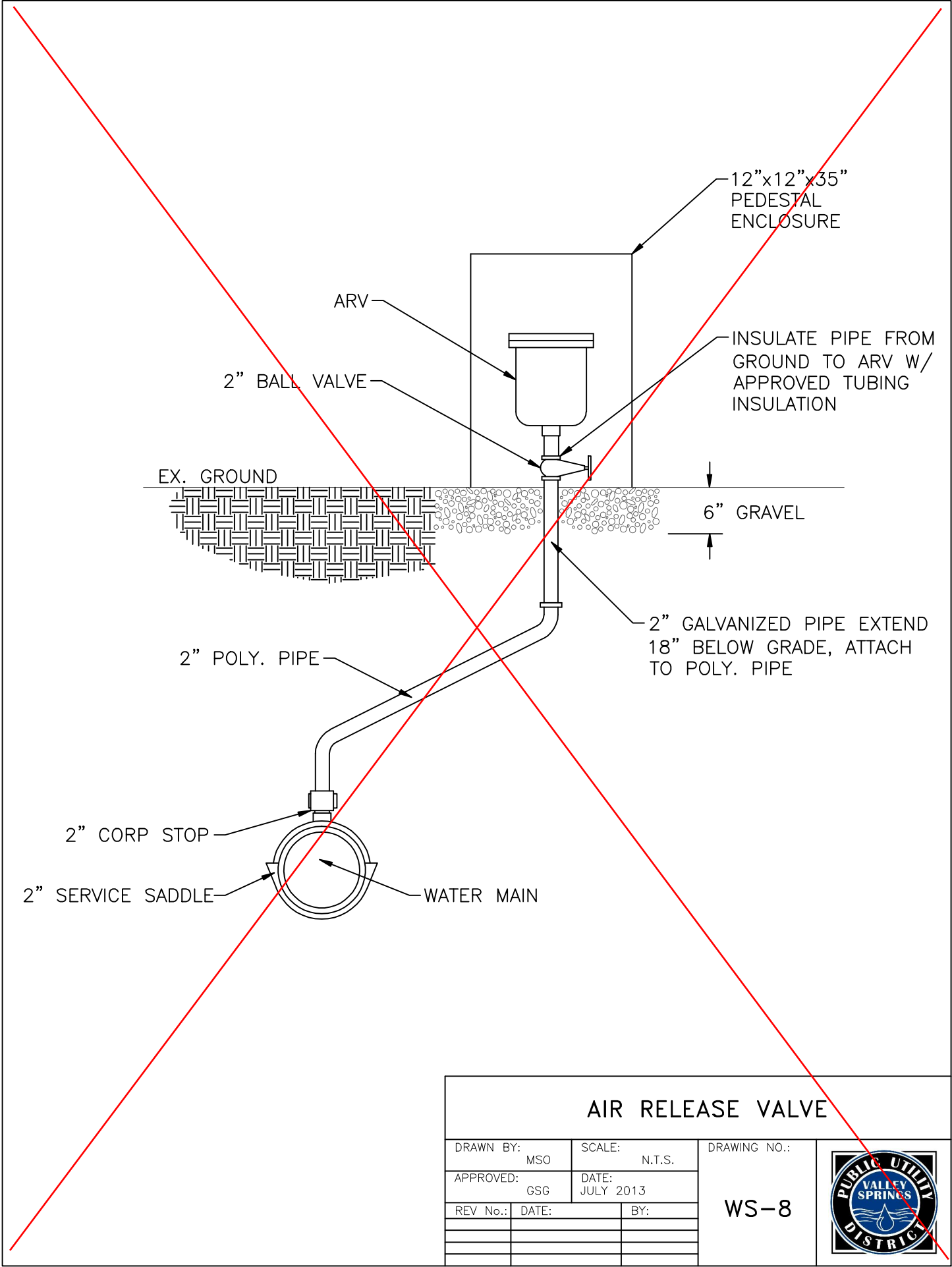

12"x12"x35"
PEDESTAL
ENCLOSURE

ARV

2" BALL VALVE

INSULATE PIPE FROM
GROUND TO ARV W/
APPROVED TUBING
INSULATION

EX. GROUND

6" GRAVEL

2" GALVANIZED PIPE EXTEND
18" BELOW GRADE, ATTACH
TO POLY. PIPE

2" POLY. PIPE

2" CORP STOP

2" SERVICE SADDLE

WATER MAIN

AIR RELEASE VALVE

DRAWN BY: MSO		SCALE: N.T.S.	DRAWING NO.:
APPROVED: GSG		DATE: JULY 2013	
REV No.:	DATE:	BY:	WS-8



NOTES:

1. VALVE BOX SHALL BE SET ADJACENT TO PROPERTY LINE IN UNIMPROVED STREETS OR BEHIND CURB IN IMPROVED STREETS.
2. SIZES OF PIPE, FITTINGS, VALVES, CORPORATION STOPS SHALL MATCH THE SIZE OF THE COMBINATION AIR VALVE AS SPECIFIED BY THE DISTRICT.
3. TOP OF BASE & BOX SHALL BE 2" ABOVE FINISHED GRADE OR LEVEL WITH SIDEWALK/PAVEMENT GRADE.
4. LOCATOR WIRE PER DETAIL WS-1.

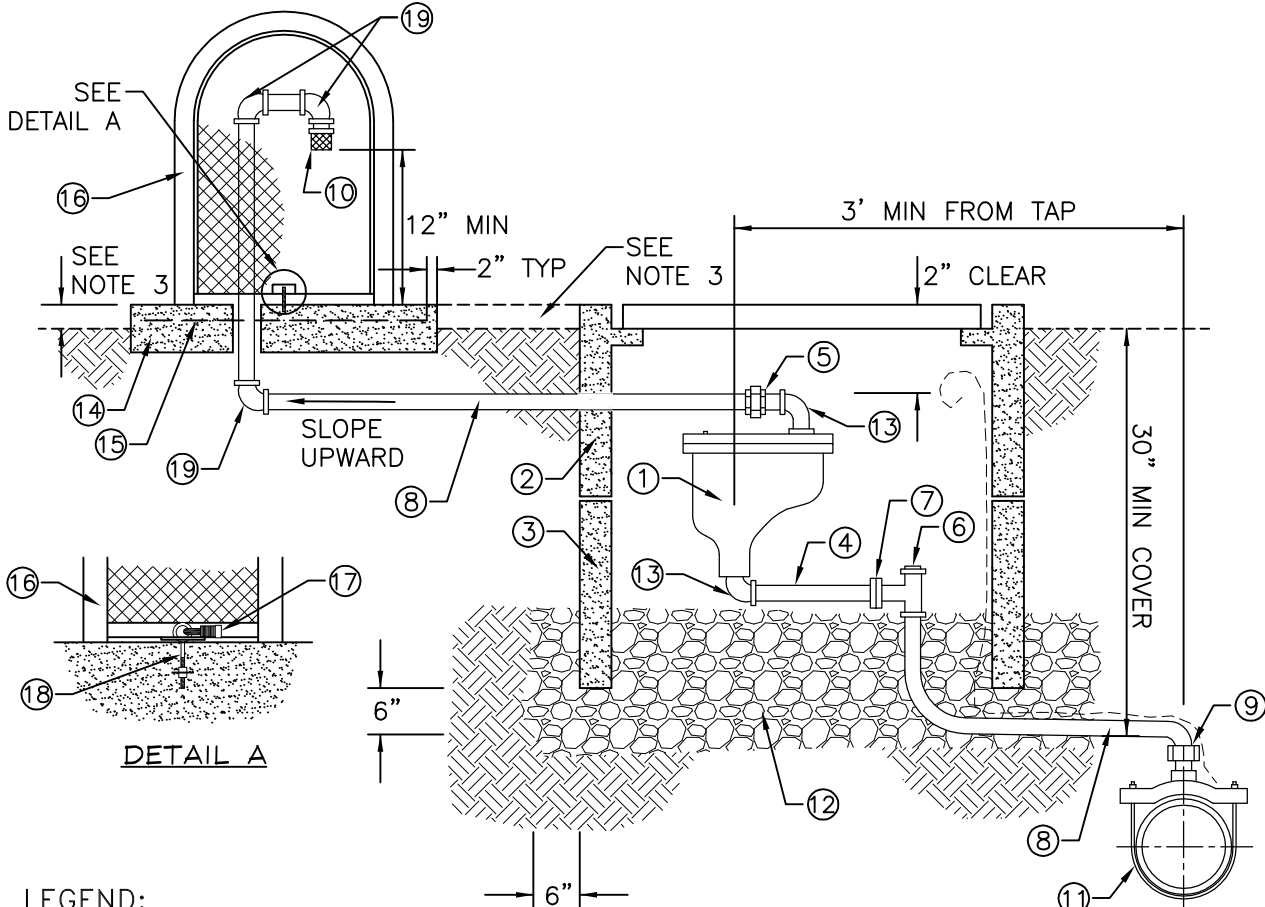

LEGEND:

- ① COMBINATION AIR VALVE (FUNCTIONS AS BOTH AIR RELEASE AND AIR/VACUUM VALVES, MIN. OPERATING RANGE OF 300 PSI.) VAL-MATIC 201C.2 (1-INCH), 202C.2 (2-INCH).
- ② VALVE BOX, CHRISTY NO. B30 WITH B30-61D COVER, WITH STEEL CHECKER PLATE COVER. TRAFFIC COVER SHALL BE USED IN TRAFFIC AREAS AND WHERE DIRECTED BY DISTRICT ENGINEER.
- ③ VALVE BOX EXTENSION, CHRISTY B30x12.
- ④ BRASS PIPE (LOW LEAD).
- ⑤ MUELLER 110 STRAIGHT COUPLING COMPRESSION CONNECTION H-15428-N.
- ⑥ BALL ANGLE METER VALVE, MUELLER B-24258-3-N FOR 1-INCH ASSEMBLY, MUELLER B-24276-3-N FOR 2-INCH ASSEMBLY.
- ⑦ MUELLER H-10889-N METER BUSHING FOR 1", BUDCO, BRASS METER FLANGE (MF) DOMESTIC (LOW LEAD) FOR 2".
- ⑧ POLYETHYLENE CTS WEST FLEX GOLD PIPE
- ⑨ CORPORATION STOPS, MUELLER B-25008-N.
- ⑩ STAINLESS STEEL MESH VENT CAP, VC-1 (1") OR VC-2 (2") ATTACHED TO A 1" OR 2" ADAPTER, COPPER SLP.
- ⑪ DOUBLE BAND BRONZE SERVICE SADDLE MUELLER BR2B "CC".
- ⑫ 3/4" DRAIN ROCK., UP TO VALVE ONLY.
- ⑬ GALVANIZED STREET ELBOW.
- ⑭ CONCRETE BASE 30"W x 20"L x 3"H.
- ⑮ STEEL WIRE MESH.
- ⑯ ENCLOSURE BPGI GS-1. COLOR SHALL BE GREEN.
- ⑰ PADLOCK (FURNISHED BY DISTRICT). ONE ON EACH SIDE OF ENCLOSURE (TYP.)
- ⑱ THREADED SS-316 EYEBOLT & WASHER W/ 7/16" MIN. I.D. EMBEDDED 2" INTO CONC.
- ⑳ 90° COPPER SWEAT

1" OR 2" COMBINATION AIR & VACUUM RELEASE VALVE

DRAWN BY: MSO		SCALE: N.T.S.	DRAWING NO.: WS-9
APPROVED: GSG		DATE: JULY 2013	
REV No.:	DATE:	BY:	
1	8/28/14	MSO	
2	9/15/14	MSO	



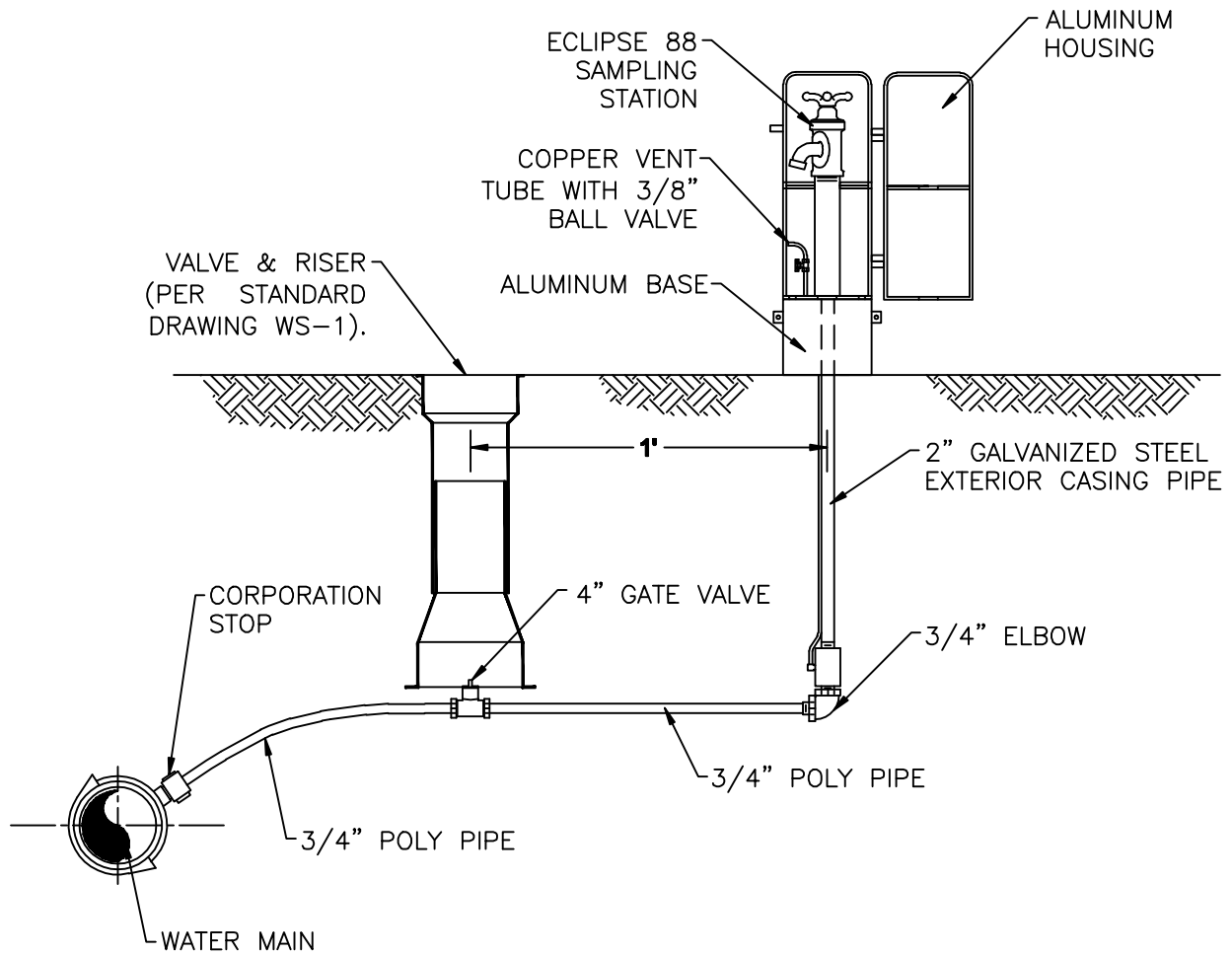

NOTES:

1. SAMPLING STATIONS SHALL BE 2' BURY, WITH A 3/4" FIP INLET, AND A (3/4" HOSE OR UNTHREADED) NOZZLE.
2. ALL STATIONS SHALL BE ENCLOSED IN A LOCKABLE, NON-REMOVABLE, ALUMINUM-CAST HOUSING.
3. WHEN OPENED, THE STATION SHALL NOT REQUIRE A KEY FOR OPERATION, AND THE WATER SHALL FLOW IN AN ALL BRASS WATERWAY.
4. ALL WORKING PARTS SHALL BE OF BRASS AND BE REMOVABLE FROM ABOVE GROUND WITH NO DIGGING. EXTERIOR PIPING SHALL BE BRASS OR GALVANIZED STEEL.
5. A COPPER VENT TUBE ENABLING EACH STATION TO BE PUMPED FREE OF STANDING WATER TO PREVENT FREEZING AND TO MINIMIZE BACTERIA GROWTH SHALL BE PROVIDED.
6. SAMPLING STATION SHALL BE ECLIPSE NO. 88 SAMPLING STATION MANUFACTURED BY KUPFERLE FOUNDRY, ST. LOUIS, MO 63102.
7. INSTALL LOCATOR WIRE PER DETAIL WS-1.

WATER QUALITY SAMPLING STATION

DRAWN BY: MSO		SCALE: N.T.S.	DRAWING NO.: WS-10	
APPROVED: GSG		DATE: JULY 2013		
REV No.:	DATE:	BY:		

NOTES:

1. ALL PROPERTY HAVING A SECOND SOURCE OF WATER, SUCH AS A WELL OR RAW IRRIGATION WATER, SHALL HAVE AN APPROVED BACKFLOW PREVENTION ASSEMBLY INSTALLED ON THE PROPERTY SIDE OF AND ADJACENT TO THE WATER METER. ALTERNATE PLACEMENT MAY BE ALLOWED SUBJECT TO DISTRICT ENGINEER APPROVAL. CONNECTIONS OF ANY SORT INTENDED TO BYPASS THE PROTECTIVE ASSEMBLY ARE PROHIBITED.
2. BACKFLOW PREVENTION ASSEMBLY SHALL NOT BE INSTALLED BELOW GRADE.
3. ALL BACKFLOW PREVENTION DEVICES SHALL CONFORM TO THE LATEST REVISED CALIFORNIA DEPARTMENT OF PUBLIC HEALTH APPROVED LIST FOR CROSS-CONNECTION.
4. THE CUSTOMER SHALL OWN AND MAINTAIN THE BACKFLOW PREVENTION ASSEMBLY AND PAY ALL COSTS TO INSPECT & TEST THE INSTALLATION.
5. INSTALL LOCATOR WIRE PER DETAIL WS-1.

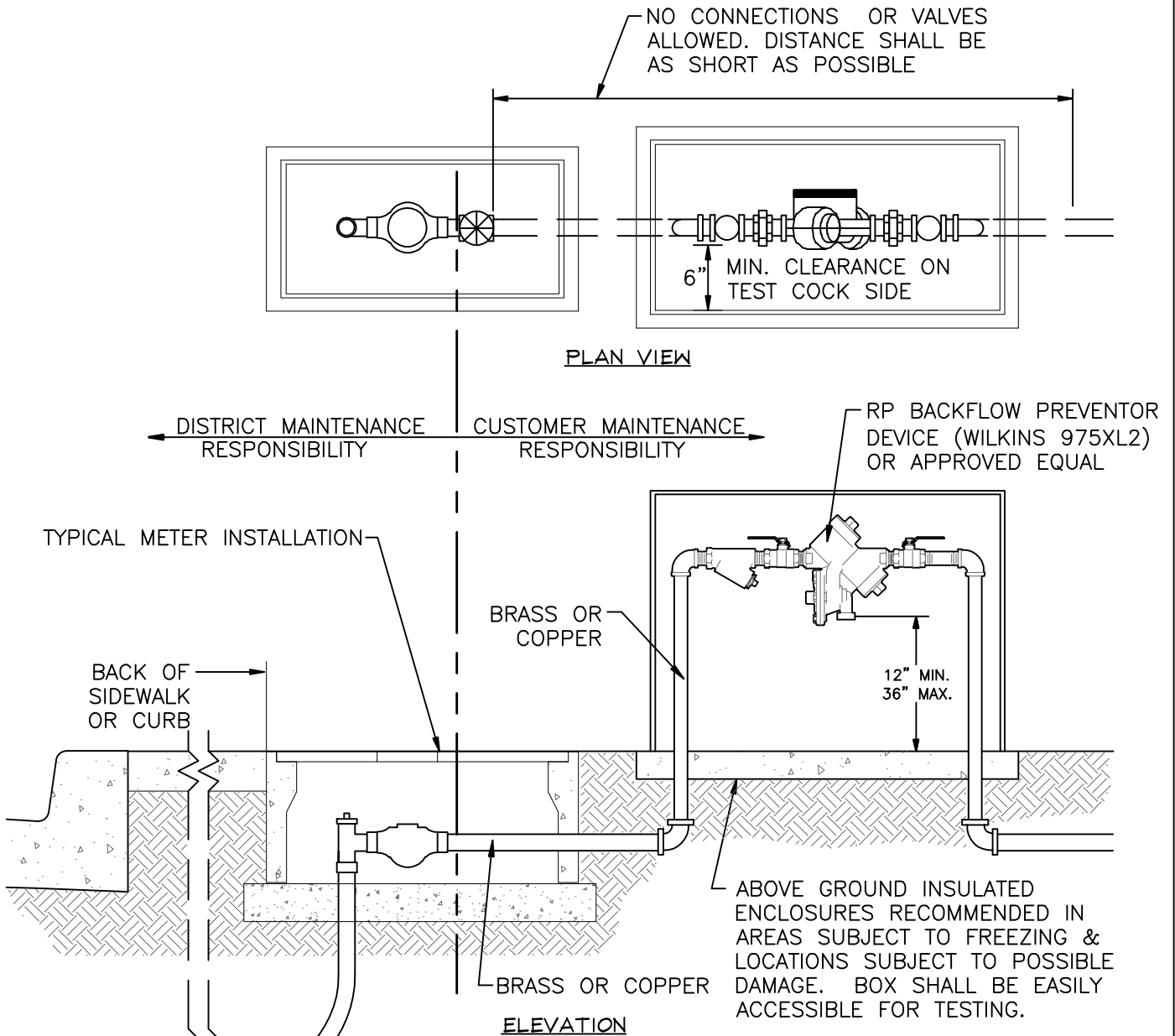

RESIDENTIAL REDUCED PRESSURE BACKFLOW PREVENTION ASSEMBLY

DRAWN BY: MSO	SCALE: N.T.S.	DRAWING NO.:
APPROVED: GSG	DATE: JULY 2013	
REV No.:	DATE:	BY:

WS-11



POLYETHYLENE CTS

NOTES:

1. ALL MECHANICAL BACKFLOW PREVENTION DEVICES SHALL CONFORM TO THE LATEST REVISED CALIFORNIA DEPARTMENT OF PUBLIC HEALTH APPROVED LIST FOR CROSS CONNECTION.
2. THE TYPE OF DEVICE (REDUCED PRESSURE PRINCIPAL ASSEMBLY OR DOUBLE CHECK/DETECTOR ASSEMBLY) SHALL BE DETERMINED BY THE DISTRICT.
3. REDUCE PRESSURE BACKFLOW ASSEMBLIES SHALL BE REQUIRED ON ALL FIRE SERVICE CONNECTIONS.
4. NO TEES OR OTHER CONNECTIONS ARE ALLOWED ON THE ASSEMBLY.
5. INSTALL BACKFLOW PREVENTION DEVICE AS CLOSE AS PRACTICAL TO THE MAIN.
6. THE CUSTOMER SHALL OWN & MAINTAIN THE BACKFLOW DEVICE AND ALL PIPING FROM MAIN.
7. CUSTOMER SHALL PAY ALL DISTRICT COSTS FOR INSPECTION AND TESTING.
8. GATE VALVE REQUIRED AT MAIN PER DETAIL WS-1.

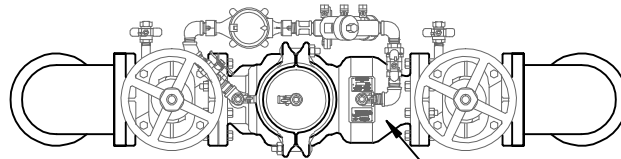

PLAN

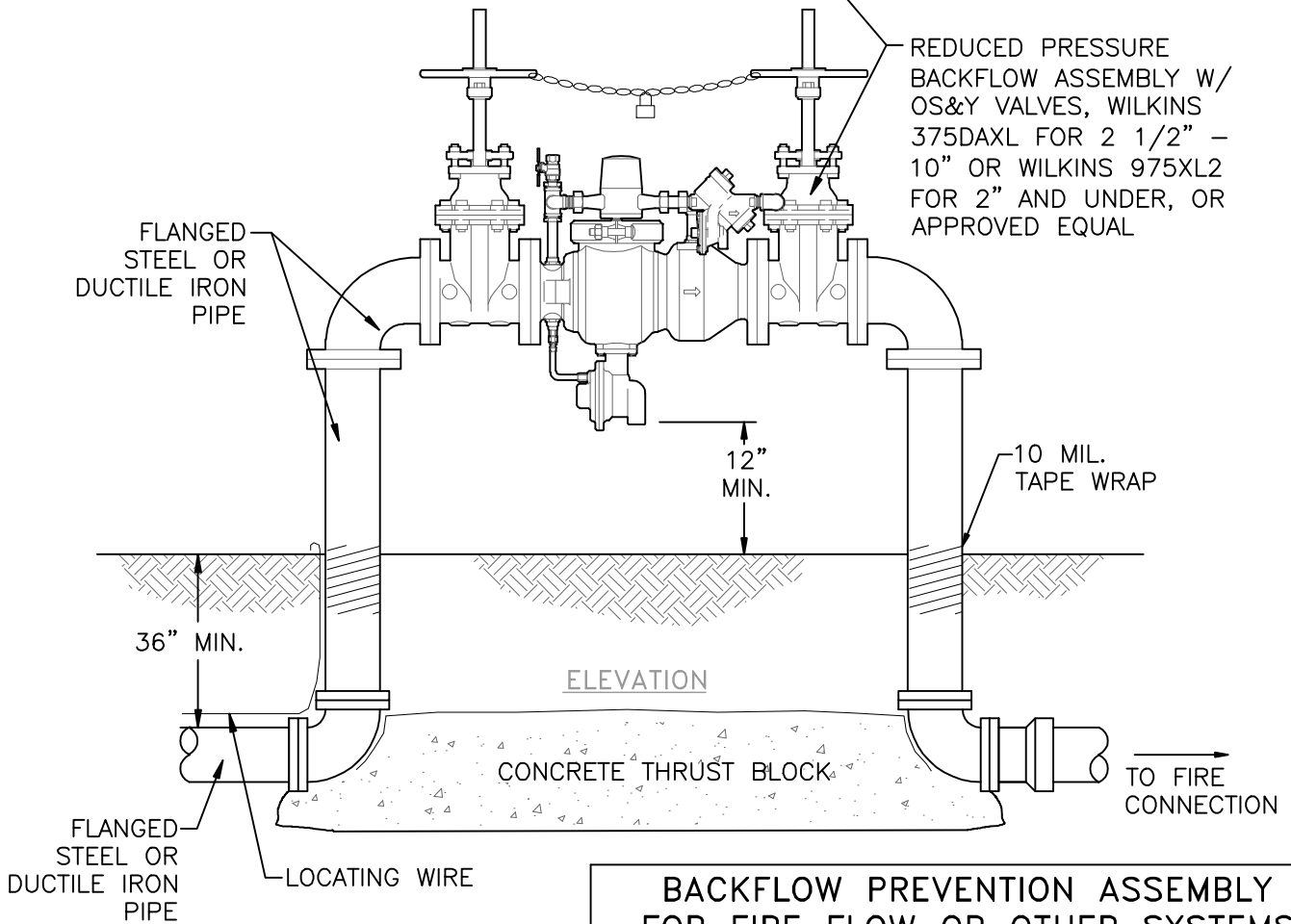

**BACKFLOW PREVENTION ASSEMBLY
FOR FIRE FLOW OR OTHER SYSTEMS**

DRAWN BY: MSO	SCALE: N.T.S.	DRAWING NO.:
APPROVED: GSG	DATE: JULY 2013	
REV No.:	DATE:	BY:

WS-12



NOTES:

1. THRUST BLOCK AREAS & VOLUMES GIVEN ARE FOR A TEST PRESSURE OF 150 psi AND A SOIL BEARING PRESSURE OF 2000 lb/sf. INSTALLATIONS USING HIGHER PRESSURES OR LOWER SOIL BEARING PRESSURES WILL REQUIRE ADJUSTMENT OF THRUST BLOCK SIZE; SUBJECT TO APPROVAL BY DISTRICT ENGINEER. CONTRACTOR SHALL CONFIRM SOIL CONDITIONS.
2. THRUST BLOCKS TO BE CONSTRUCTED OF CLASS "B" CONCRETE & SHALL BE POURED AGAINST UNDISTURBED SOIL.
3. WRAP ALL FITTINGS, NUTS, & BOLTS WITH 6 MIL. POLYETHYLENE FILM.
4. JOINTS, FACE OF PLUGS AND NUTS & BOLTS TO BE KEPT CLEAR OF CONCRETE AND MUST BE ABLE TO OPERATE WITHOUT DISTURBING THRUST BLOCK.
5. VERTICAL BENDS SHALL USE RESTRAINED JOINTS AND A FULL LENGTH OF PIPE ON EACH SIDE OF FITTING.
6. #4 REBAR SHALL BE PLACED AS SHOWN WITH 12" MINIMUM EMBEDMENT. REBAR STIRRUPS TO BE SHAPED WITH 90° BEND AT EACH END AND COATED WITH TWO COATS OF KOPPERS 505 OR EQUAL, 15 MILS EACH COAT. PLACE 14 GA. GALV. PLATE BETWEEN REBAR AND PIPE.
7. THRUST BLOCKS FOR REDUCERS SHALL HAVE A MINIMUM BEARING AREA OF 10 SF.

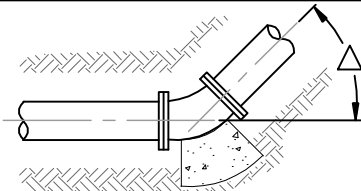
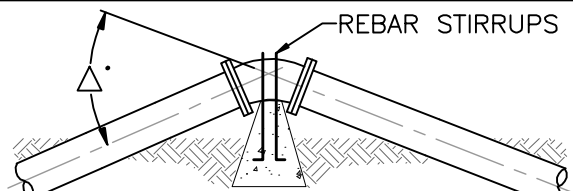
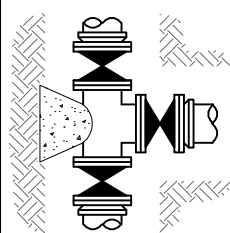
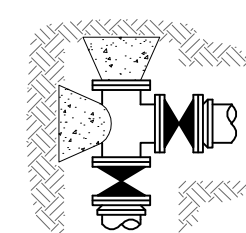
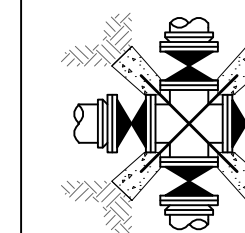
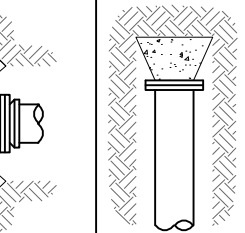
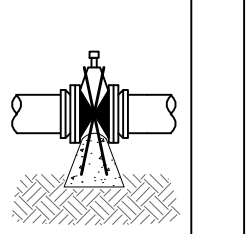
		 <p>PLAN</p>				 <p>ELEVATION</p>				
NOMINAL PIPE DIA. (IN.)	HORIZONTAL THRUST BLOCK				VERTICAL THRUST BLOCK					
	BEARING AREA (SQ. FT.)				VOLUME OF CONCRETE (CU. YD.)					
	Δ =11 1/4'	Δ =22 1/2'	Δ =45'	Δ =90'	Δ =11 1/4'	Δ =22 1/2'	Δ =45'	Δ =90'		
4"	1.0	1.0	1.0	2.0	0.5	0.5	1.0	1.0		
6"	2.0	2.0	3.0	4.0	0.5	0.5	1.0	2.0		
8"	2.0	2.0	4.0	7.0	0.5	1.0	2.0	3.5		
10"	3.0	3.0	6.0	12.0	1.0	1.5	3.0	5.5		
12"	5.0	5.0	9.0	16.0	1.3	2.2	4.3	7.9		
NOMINAL PIPE DIA. (IN.)										
		TEE	TEE W/ BLD. FLG.	CROSS	DEAD END	IN LINE VALVE				
4"	2.0	2.0	2.0	2.0	2.0	1.3				
6"	3.0	3.0	4.0	3.0	2.8					
8"	5.0	5.0	7.0	5.0	5.0					
10"	8.0	8.0	12.0	8.0	7.8					
12"	12.0	12.0	16.0	12.0	11.3					
EACH HORIZONTAL THRUST BLOCK BEARING AREA (SQ. FT.)										

THRUST BLOCK DETAILS

DRAWN BY: MSO	SCALE: N.T.S.	DRAWING NO.:
APPROVED: GSG	DATE: JULY 2013	
REV No.:	DATE:	BY:

WS-13



NOTES:

1. SKIDS OF CARRIER PIPE SUPPORTS SHALL BE GREASED BEFORE INSTALLATION.
2. SPACING OF CARRIER PIPE SUPPORTS SHALL BE PER MANUFACTURES' RECOMMENDATION OR 9', WHICHEVER IS LESS.
3. CARRIER PIPE SHALL BE TESTED BEFORE SEALING ENDS.
4. BELLS OF CARRIER PIPE SHALL NOT REST ON CASING PIPE.
5. CASING LENGTH & THICKNESS SHALL CONFORM TO DISTRICT STANDARDS OR CALTRANS SPECIFICATIONS, WHICHEVER ARE MORE STRINGENT.
6. VALVES SHALL BE LOCATED ON EACH SIDE OF CASING AS DIRECTED BY THE DISTRICT.

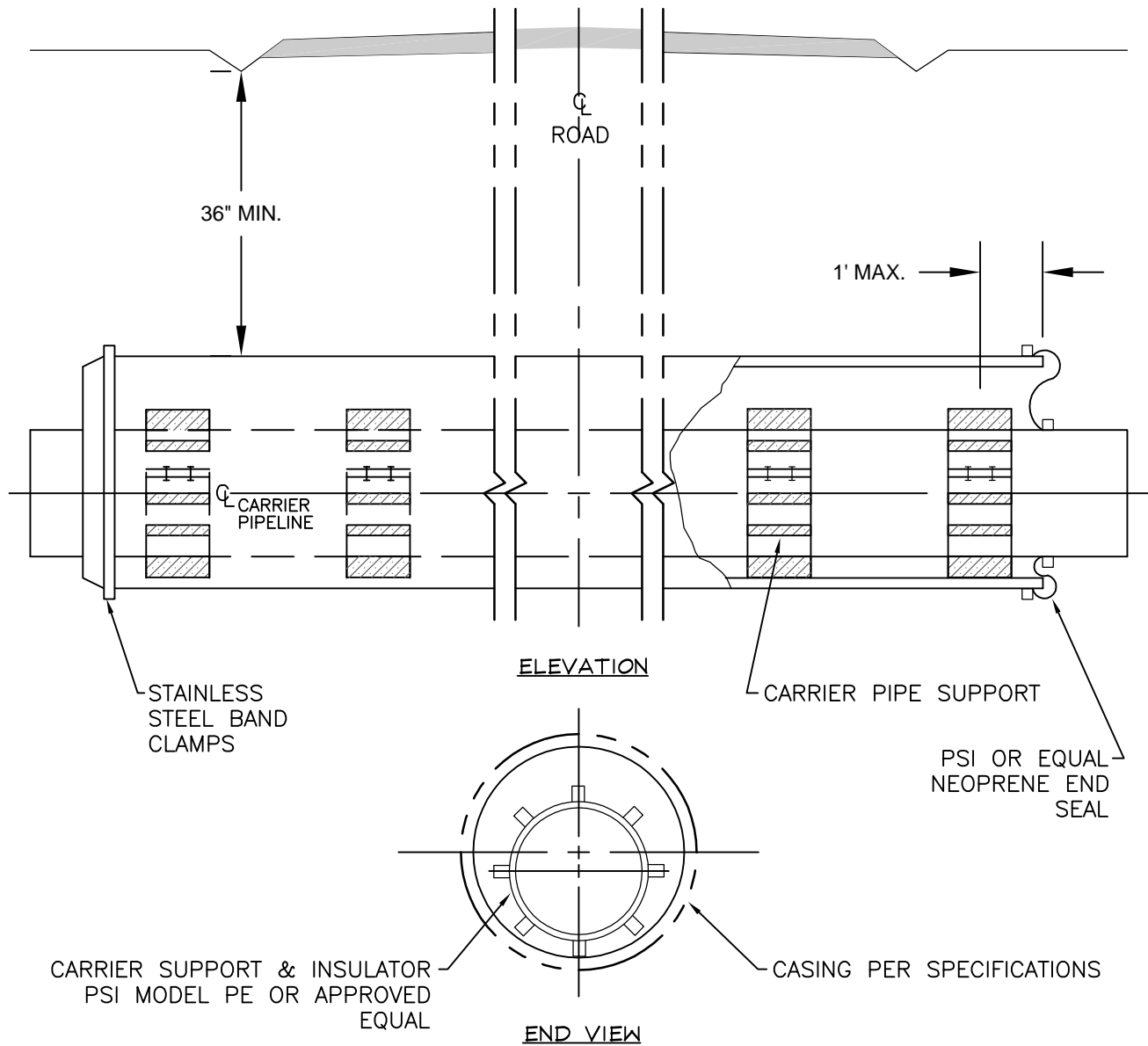

CASING & CARRIER PIPE			
DRAWN BY: MSO	SCALE: N.T.S.	DRAWING NO.:	
APPROVED: GSG	DATE: JULY 2013	WS-14	
REV No.: 1	DATE: 6/30/14		

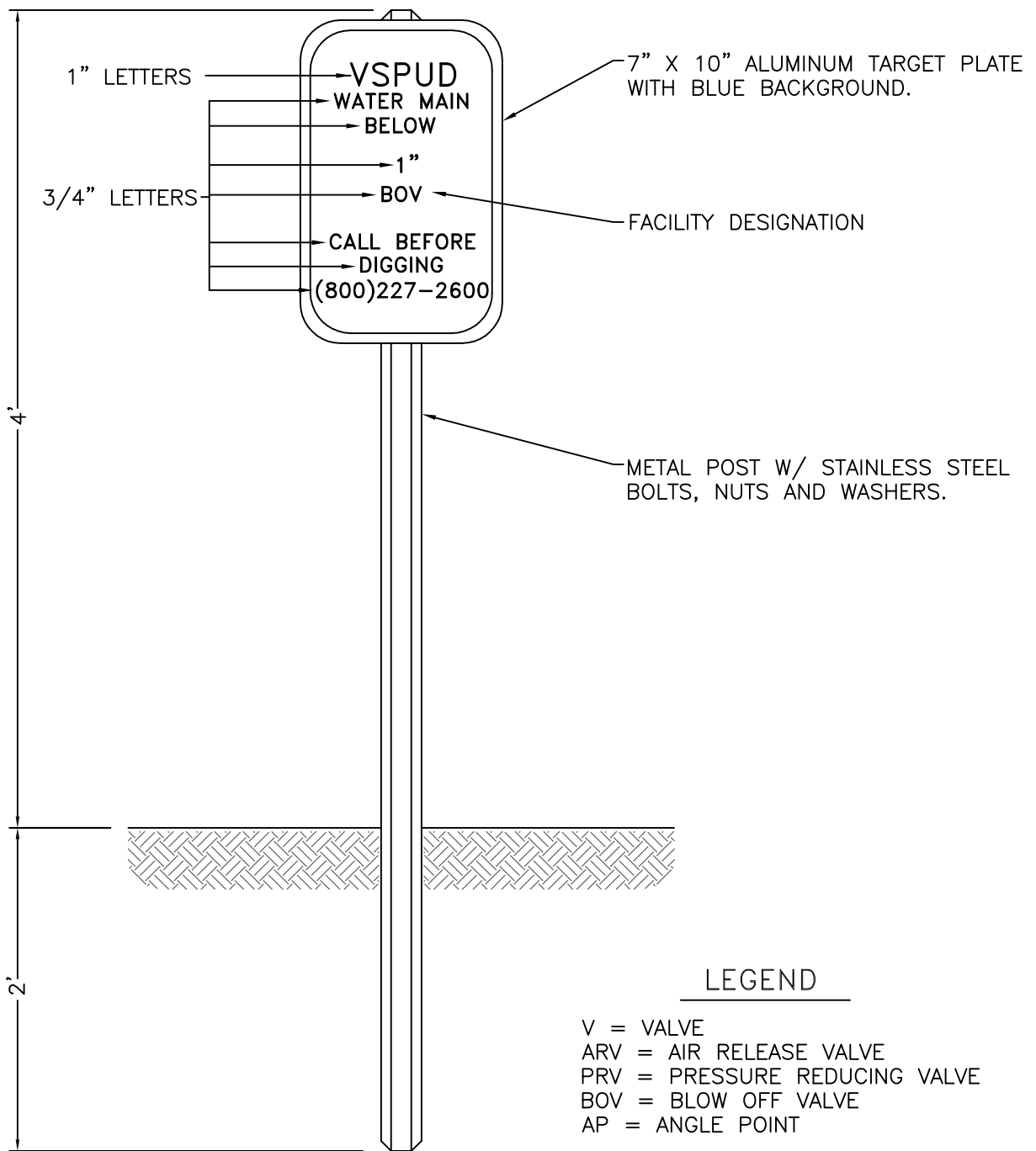

LEGEND

- V = VALVE
- ARV = AIR RELEASE VALVE
- PRV = PRESSURE REDUCING VALVE
- BOV = BLOW OFF VALVE
- AP = ANGLE POINT

NOTES:

1. LOCATION OF MARKER SHALL BE APPROVED BY DISTRICT ENGINEER BEFORE PLACEMENT.
2. TARGET PLATE & POST SHALL CONFORM TO SECTION 82 OF CALIFORNIA STANDARD SPECIFICATIONS.
3. ALL NUMBERS AND LETTERS SHALL BE STENCILED IN WHITE.

WATER FACILITY MARKER			
DRAWN BY:	MSO	SCALE:	N.T.S.
APPROVED:	GSG	DATE:	JULY 2013
REV No.:	DATE:	BY:	
DRAWING NO.:			WS-15
			

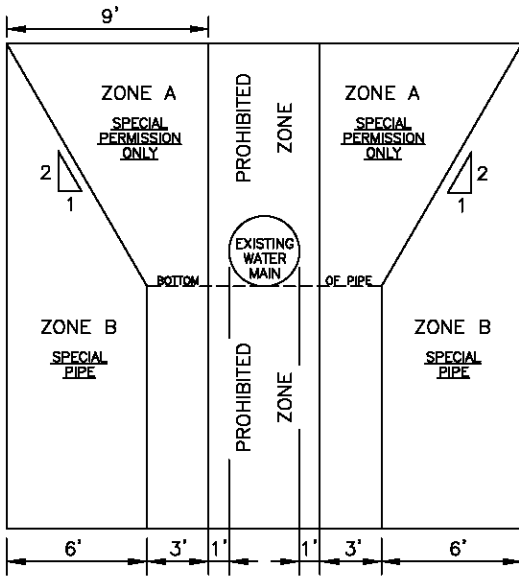

CASE 1 PARALLEL CONSTRUCTION
NEW SEWER - EXISTING WATER

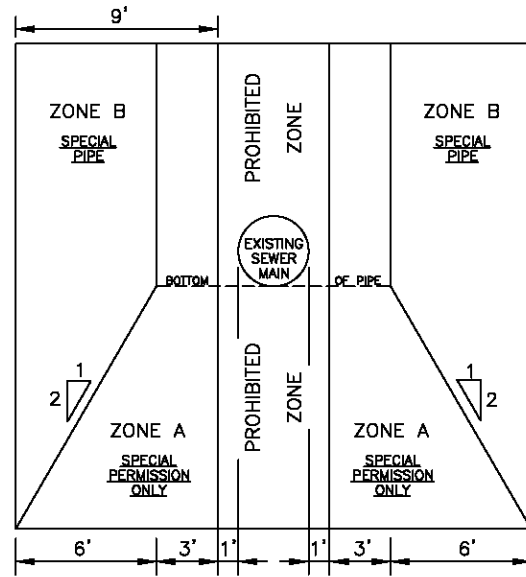

CASE 2 PARALLEL CONSTRUCTION
NEW WATER - EXISTING SEWER

ZONE A: SEWER LINES NOT PERMITTED WITHOUT WRITTEN PERMISSION FROM COUNTY ENVIRONMENTAL HEALTH AND VSPUD

ZONE B: NEW SEWER MAIN SHALL BE CONSTRUCTED OF:
PVC PIPE WITH RUBBER RING JOINTS (ASTM D3034)
CAST OR DUCTILE IRON PIPE WITH COMPRESSION JOINTS

ZONE A: WATER LINES NOT PERMITTED WITHOUT WRITTEN PERMISSION FROM COUNTY ENVIRONMENTAL HEALTH AND VSPUD

ZONE B: IF EXISTING SEWER MAIN DOES NOT MEET CASE 1 - ZONE B REQUIREMENTS NEW WATER MAIN SHALL BE:
CLASS 200 PVC (DR 14 / AWWA C900-97)
DUCTILE IRON PIPE WITH HOT DIP BITUMINOUS COATING
DIPPED & WRAPPED 1/4" WALL WELDED STEEL PIPE

WATER MAIN SEPARATION:

- A. NEW WATER MAINS AND NEW SUPPLY LINES SHALL BE INSTALLED AT LEAST 10 FEET HORIZONTALLY FROM AND ONE FOOT VERTICALLY ABOVE ANY PARALLEL PIPELINE CONVEYING:
 - 1 - UNTREATED SEWAGE
 - 2 - PRIMARY OR SECONDARY TREATED SEWAGE
 - 3 - DISINFECTED SECONDARY-2.2 OR 23 RECYCLED WATER (AS DEFINED IN SECTIONS 60301.220 & 60301.225*)
 - 4 - HAZARDOUS FLUIDS SUCH AS FUELS, INDUSTRIAL WASTES AND WASTEWATER SLUDGE
- B. NEW WATER MAINS AND NEW SUPPLY LINES SHALL BE INSTALLED AT LEAST 4 FEET HORIZONTALLY FROM AND ONE FOOT VERTICALLY ABOVE ANY PARALLEL PIPELINE CONVEYING:
 - 1 - DISINFECTED TERTIARY RECYCLED WATER (AS DEFINED IN SECTION 60301.230*)
 - 2 - STORM DRAINAGE PIPES OR CATCHMENTS
- C. NEW SUPPLY LINES CONVEYING RAW WATER TO BE TREATED FOR DRINKING PURPOSES SHALL BE INSTALLED AT LEAST 4 FEET HORIZONTALLY FROM AND ONE FOOT VERTICALLY BELOW ANY WATER MAIN
- D. IF CROSSING A PIPELINE CONVEYING A FLUID LISTED IN (A) OR (B) ABOVE, A NEW WATER MAIN SHALL BE CONSTRUCTED PERPENDICULAR TO AND AT LEAST ONE FOOT ABOVE THAT PIPELINE. NO CONNECTION JOINTS SHALL BE MADE IN THE WATER MAIN WITHIN EIGHT HORIZONTAL FEET OF SAID FLUID PIPELINE
- E. THE VERTICAL SEPARATION SPECIFIED IN (A) (B) & (C) IS REQUIRED ONLY WHEN THE HORIZONTAL DISTANCE BETWEEN A WATER MAIN AND PIPELINE IS ELEVEN FEET OR LESS AS MEASURED FROM THE OUTSIDE EDGE OF EACH PIPE
- F. NEW WATER MAINS AND NEW SUPPLY LINES SHALL NOT BE INSTALLED WITHIN 100 FEET HORIZONTALLY OF ANY SANITARY LANDFILL, WASTEWATER DISPOSAL POND, OR HAZARDOUS WASTE DISPOSAL SITE, OR WITHIN 25 FEET OF ANY CESSPOOL, SEPTIC TANK, SEWAGE LEACH FIELD, SEEPAGE PIT OR GROUNDWATER RECHARGE PROJECT SITE.
- G. THE MINIMUM SEPARATION DISTANCES SET FORTH IN THIS SECTION SHALL BE MEASURED FROM THE NEAREST OUTSIDE EDGE OF PIPE TO THE NEAREST OUTSIDE EDGE OF PIPE IN ALL CASES

*REFERENCED IN CALIFORNIA ADMINISTRATIVE CODE, TITLE 22

NOTES:

- 1. THE ABOVE CONSTRUCTION CRITERIA APPLIES TO HOUSE SEWER LATERALS CROSSING ABOVE A WATER MAIN
- 2. SEWER LINES LARGER THAN 24" DIAMETER AND SEWER LINES WITHIN 25 FEET OF LOW-HEAD WATER MAIN SHALL BE REVIEWED AND APPROVED BY COUNTY ENVIRONMENTAL HEALTH DEPT.
- 3. IN NO CASE SHALL WATER MAINS AND ANY NON-POTABLE PIPELINE CONVEYING SEWAGE OR ANY OTHER FLUID NOTED ABOVE BE INSTALLED IN THE SAME TRENCH

WATER SEPARATION STANDARDS

DRAWN BY: MSO	SCALE: N.T.S.	DRAWING NO.:
APPROVED: GSG	DATE: JULY 2013	WS-16
REV No.:	DATE:	

